

User Manual

PV Grid-Connected Inverter

SG25CX-P2/SG30CX-P2/SG33CX-P2/SG36CX-P2/
SG40CX-P2/SG50CX-P2



All Rights Reserved

All Rights Reserved

No part of this document can be reproduced in any form or by any means without the prior written permission of Sungrow Power Supply Co., Ltd (hereinafter "SUNGROW").

Trademarks

SUNGROW and other SUNGROW trademarks used in this manual are owned by SUNGROW.

All other trademarks or registered trademarks mentioned in this manual are owned by their respective owners.

Software Licenses

- It is prohibited to use data contained in firmware or software developed by SUNGROW, in part or in full, for commercial purposes by any means.
- It is prohibited to perform reverse engineering, cracking, or any other operations that compromise the original program design of the software developed by SUNGROW.

About This Manual

The manual mainly contains the product information, as well as guidelines for installation, operation, and maintenance. The manual does not include complete information about the photovoltaic (PV) system. Readers can get additional information at www.sungrowpower.com or on the webpage of the respective component manufacturer.

Validity

This manual is valid for the following model of low-power grid-connected PV string inverters:

- SG25CX-P2
- SG30CX-P2
- SG33CX-P2
- SG36CX-P2
- SG40CX-P2
- SG50CX-P2

It will be referred to as "inverter" hereinafter unless otherwise specified.

Target Group

This manual is intended for professional technicians who are responsible for installation, operation, and maintenance of inverters, and users who need to check inverter parameters.

The inverter must only be installed by professional technicians. The professional technician is required to meet the following requirements:

- Know electronic, electrical wiring and mechanical expertise, and be familiar with electrical and mechanical schematics.
- Have received professional training related to the installation and commissioning of electrical equipment.
- Be able to quickly respond to hazards or emergencies that occur during installation and commissioning.
- Be familiar with local standards and relevant safety regulations of electrical systems.
- Read this manual thoroughly and understand the safety instructions related to operations.

How to Use This Manual

Please read this manual carefully before using the product and keep it properly at a place for easy access.

All contents, pictures, marks, and symbols in this manual are owned by SUNGROW. No part of this document may be reprinted by the non-internal staff of SUNGROW without written authorization.

Contents of this manual may be periodically updated or revised, and the actual product purchased shall prevail. Users can obtain the latest manual from support.sungrowpower.com or sales channels.

Security Declaration

For details on the product's network security vulnerability response process and vulnerability disclosure, please visit the following website: <https://en.sungrowpower.com/security-vulnerability-management>.

For more information on network security, please refer to the user manual of the communication module or the Data Logger that comes with the product.

Symbols

This manual contains important safety instructions, which are highlighted with the following symbols, to ensure personal and property safety during usage, or to help optimize the product performance in an efficient way.

Please carefully understand the meaning of these warning symbols to better use the manual.

DANGER

Indicates high-risk potential hazards that, if not avoided, may lead to death or serious injury.

WARNING

Indicates moderate-risk potential hazards that, if not avoided, may lead to death or serious injury.

CAUTION

Indicates low-risk potential hazards that, if not avoided, may lead to minor or moderate injury.

NOTICE

Indicates potential risks that, if not avoided, may lead to device malfunctions or financial losses.



“NOTE” indicates additional information, emphasized contents or tips that may be helpful, e.g., to help you solve problems or save time.

Contents

All Rights Reserved.....	I
About This Manual.....	II
1 Safety Instructions.....	1
1.1 Unpacking and Inspection.....	2
1.2 Installation Safety.....	3
1.3 Electrical Connection Safety.....	3
1.4 Operation Safety.....	5
1.5 Maintenance Safety.....	6
1.6 Disposal Safety.....	7
2 Product Description.....	8
2.1 System Introduction.....	8
2.2 Product Introduction.....	10
2.3 Symbols on Product.....	12
2.4 LED Indicator.....	13
2.5 Circuit Diagram.....	14
2.6 Function Description.....	15
3 Unpacking and Storage.....	20
3.1 Unpacking and Inspection.....	20
3.2 Inverter Storage.....	20
4 Mechanical Mounting.....	22
4.1 Safety During Mounting.....	22
4.2 Location Requirements.....	23
4.2.1 Installation Environment Requirements.....	24
4.2.2 Carrier Requirements.....	26
4.2.3 Angle Requirements.....	26
4.2.4 Clearance Requirements.....	28
4.3 Installation Tools.....	29
4.4 Moving the Inverter.....	31
4.5 Installing Mounting-bracket.....	32
4.5.1 Bracket-Mounted Installation.....	32
4.5.2 Wall-Mounted Installation.....	33
4.5.3 Pole Installation.....	35
4.6 Installing the Inverter.....	36
4.7 Installing Optimizer(Optional).....	38

4.8 Installing the RSD (Optional).....	38
5 Electrical Connection.....	39
5.1 Safety Instructions.....	39
5.2 Terminal Description.....	41
5.3 Electrical Connection Overview.....	43
5.4 Crimp OT/DT terminal.....	46
5.5 External Protective Grounding Connection.....	47
5.5.1 External Protective Grounding Requirements.....	48
5.5.2 Connection Procedure.....	48
5.6 AC Cable Connection.....	49
5.6.1 AC Side Requirements.....	49
5.6.2 Requirements for OT/DT Terminal.....	50
5.6.3 Connection Procedure.....	51
5.7 DC Cable Connection.....	54
5.7.1 PV Input Configuration.....	56
5.7.2 Assembling PV Connectors.....	57
5.7.3 Installing PV Connector.....	58
5.8 Communication Connection.....	63
5.8.1 Wireless Communication Module Connection (optional).....	63
5.8.2 WiNet-S/WiNet-S2 Connection (optional).....	64
5.8.2.1 Ethernet Communication.....	64
5.8.2.2 WLAN Communication.....	66
5.8.3 RS485 Connection.....	67
5.8.3.1 Assembling the COM Connector.....	67
5.8.3.2 Installing the COM Connector.....	69
5.8.4 Smart Energy Meter Connection.....	70
5.8.5 Dry Contact Connection.....	71
5.8.5.1 Dry Contact Function.....	71
5.8.5.2 Wiring Procedure.....	73
5.8.6 DRM Connection.....	73
5.8.6.1 Assembling the COM Connector.....	74
5.8.6.2 Installing the COM Connector.....	76
6 Commissioning.....	78
6.1 Inspection Before Commissioning.....	78
6.2 Commissioning Procedure.....	78
6.3 Optimizer Physical Layout (Optional).....	79
7 iSolarCloud App.....	81
7.1 About iSolarCloud.....	81
7.2 Install iSolarCloud.....	82

7.3 User Roles.....	83
7.4 Device Commissioning.....	83
8 System Decommissioning.....	84
8.1 Disconnecting the Inverter.....	84
8.2 Dismantling the Inverter.....	84
8.3 Replacing the Inverter.....	85
8.3.1 Replacement via Communication Module/Logger.....	85
8.3.2 Replacement via iSolarCloud.....	85
8.4 Disposal of Inverter.....	87
9 Troubleshooting and Maintenance.....	88
9.1 Troubleshooting.....	88
9.2 Maintenance.....	97
9.2.1 Maintenance Notices.....	97
9.2.2 Rapid Shutdown.....	98
9.2.3 Routine Maintenance.....	98
9.2.4 Cleaning Air Inlet and Outlet.....	99
9.2.5 Fan Maintenance.....	99
10 Appendix.....	101
10.1 Technical Data.....	101
10.2 Wring Distance of DI Dry Contact.....	110
10.3 Quality Assurance.....	111
10.4 Contact Information.....	112

1 Safety Instructions

When installing, commissioning, operating, and maintaining the product, strictly observe the labels on the product and the safety requirements in the manual. Incorrect operation or work may cause:

- Injury or death to the operator or a third party.
- Damage to the product and other properties.

WARNING

- **Do not perform any operation on the product (including but not limited to, handling, installing, powering on, or maintaining the product, performing electrical connection, and working at heights) in harsh weather conditions, such as thunder and lightning, rain, snow, and Level 6 or stronger winds. SUNGROW shall not be held liable for any damage to the device due to force majeure, such as earthquakes, floods, volcanic eruptions, mudslides, lightning strikes, fires, wars, armed conflicts, typhoons, hurricanes, tornadoes, and other extreme weathers.**
- **In case of fire, evacuate from the building or product area and call the fire alarm. Re-entry into the burning area is strictly prohibited under any circumstances.**

NOTICE

- **Tighten the screws with the specified torque using tools when fastening the product and terminals. Otherwise, the product may be damaged. And the damage caused is not covered by the warranty.**
- **Learn how to use tools correctly before using them to avoid hurting people or damaging the device.**
- **Maintain the device with sufficient knowledge of this manual and use proper tools.**



- The safety instructions in this manual are only supplements and cannot cover all the precautions that should be followed. Perform operations considering actual onsite conditions.
- SUNGROW shall not be held liable for any damage caused by violation of general safety operation requirements, general safety standards, or any safety instruction in this manual.
- When installing, operating, and maintaining the product, comply with local laws and regulations. The safety precautions in this manual are only supplements to local laws and regulations.
- During the product transport, installation, wiring, maintenance, etc., the materials and tools prepared by users must meet the requirements of applicable local laws and regulations, safety standards, and other specifications. SUNGROW shall not be held liable for any damage to the product caused by the adoption of materials and tools that fail to meet the above-mentioned requirements.
- Operations on the product, including but not limited to, handling, installing, wiring, powering on, maintenance, and use of the product, must not be performed by unqualified personnel. SUNGROW shall not be held liable for any damage to the product resulting from operations done by unqualified personnel.
- Where the transport of the product is arranged by users, SUNGROW shall not be held liable for any damage to the product that is caused by users themselves or the third-party transport service providers designated by the users.
- SUNGROW shall not be held liable for any damage to the product caused by the negligence, intent, fault, improper operation, and other behaviors of users or third-party organizations.
- SUNGROW shall not be held liable for any damage to the product arising from reasons unrelated to SUNGROW.

1.1 Unpacking and Inspection

WARNING

- **Check all safety signs, warning labels and nameplates on devices.**
- **The safety signs, warning labels and nameplates must be clearly visible and cannot be removed or covered before the device is decommissioned.**

NOTICE

After receiving the product, check whether the appearance and structural parts of the device are damaged, and check whether the packing list is consistent with the actual ordered product. If there are problems with the above inspection items, do not install the device and contact your distributor first. If the problem persists, contact SUNGROW in time.

1.2 Installation Safety

⚠ DANGER

- Make sure there is no electrical connection before installation.
- Before drilling, avoid the water and electricity wiring in the wall.

⚠ CAUTION

Improper installation may cause personal injury!

- If the product supports hoisting transport and is hoisted by hoisting tools, no one is allowed to stay under the product.
- When moving the product, be aware of the product weight and keep the balance to prevent it from tilting or falling.

NOTICE

Before operating the product, must check and ensure that tools to be used have been maintained regularly.

1.3 Electrical Connection Safety

⚠ DANGER

- Before electrical connections, please make sure that the inverter is not damaged, otherwise it may cause danger!
- Before electrical connections, please make sure that the inverter switch and all switches connected to the inverter are set to "OFF", otherwise electric shock may occur!

⚠ DANGER

The PV string will generate lethal high voltage when exposed to sunlight.

- Operators must wear proper personal protective equipment during electrical connections.
- Must ensure that cables are voltage-free with a measuring instrument before touching DC cables.
- Respect all safety instructions listed in relevant documents about PV strings.
- The inverter must not be connected to a PV string that requires positive or negative grounding.

⚠ DANGER

Danger to life due to a high voltage inside the inverter!

- Be sure to use special insulation tools during cable connections.
- Note and observe the warning labels on the product, and perform operations strictly following the safety instructions.
- Respect all safety instructions listed in this manual and other pertinent documents.

⚠ WARNING

Damage to the product caused by incorrect wiring is not covered by the warranty.

- Electrical connection must be performed by professionals.
- All cables used in the PV generation system must be firmly attached, properly insulated, and adequately dimensioned.

⚠ WARNING

- Check the positive and negative polarity of the PV strings, and connect the PV connectors to corresponding terminals only after ensuring polarity correctness.
- During the installation and operation of the inverter, please ensure that the positive or negative poles of PV strings do not short-circuit to the ground. Otherwise, an AC or DC short-circuit may occur, resulting in equipment damage. The damage caused by this is not covered by the warranty.
- Do not connect any load between the inverter and the AC circuit breaker directly connected to it, so as to prevent the switch from tripping by mistake.
- Determine the specifications of AC circuit breakers strictly in compliance with the applicable local laws and regulations and safety standards or the recommendation by SUNGROW. Otherwise, the switch may not open in time in the event of something abnormal, which may then lead to safety incidents.

NOTICE

Comply with the safety instructions related to PV strings and the regulations related to the local grid.

1.4 Operation Safety

⚠ DANGER

When routing cables, ensure a distance of at least 30 mm between the cables and heat-generating components or areas to protect the insulation layer of cables from aging and damage.

When the product is working:

- Do not touch the product enclosure.
- It is strictly forbidden to plug and unplug any connector on the inverter.
- Do not touch any wiring terminal of the inverter. Otherwise, electric shock may occur.
- Do not disassemble any parts of the inverter. Otherwise, electric shock may occur.
- It is strictly forbidden to touch any hot parts of the inverter (such as the heat sink). Otherwise, it may cause burns.
- Do not connect or remove any PV string or any PV module in a string. Otherwise, electric shock may occur.
- If the inverter is equipped with a DC switch, do not operate it. Otherwise, it may cause device damage or personal injury.

Do not take other actions, such as setting parameters or cutting off power, during the process of inverter firmware update, to avoid update failure.

1.5 Maintenance Safety

DANGER

Risk of inverter damage or personal injury due to incorrect service!

- Before maintenance, disconnect the AC circuit breaker on the grid side and then the DC switch. If a fault that may cause personal injury or device damage is found before maintenance, disconnect the AC circuit breaker and wait until the night before operating the DC switch. Otherwise, a fire inside the product or an explosion may occur, causing personal injuries.
- After the inverter is powered off for 15 minutes, measure the voltage and current with professional instrument. Only when there is no voltage nor current can operators who wear protective equipment operate and maintain the inverter.
- Even if the inverter is shut down, it may still be hot and cause burns. Wear protective gloves before operating the inverter after it cools down.

DANGER

Touching the power grid or the contact points and terminals on the inverter connected to the power grid may lead to electric shock!

- The power grid side may generate voltage. Always use a standard voltmeter to ensure that there is no voltage before touching.

CAUTION

To prevent misuse or accidents caused by unrelated personnel, post prominent warning signs or demarcate safety warning areas around the product.

NOTICE

To avoid the risk of electric shock, do not perform any other maintenance operations beyond those described in this manual. If necessary, contact your distributor first. If the problem persists, contact SUNGROW. Otherwise, the losses caused is not covered by the warranty.

NOTICE

- If the paint on the inverter enclosure falls or rusts, repair it in time. Otherwise, the inverter performance may be affected.
- Do not use cleaning agents to clean the inverter. Otherwise, the inverter may be damaged, and the loss caused is not covered by the warranty.
- As the inverter contains no parts that can be maintained, never open the enclosure of the inverter or replace any internal components without authorization. Otherwise, the loss caused is not covered by the warranty.
- Do not open the maintenance door in rainy or snowy weather. If it is inevitable, take proper protective measures to avoid the ingress of rainwater and snow into the maintenance compartment; otherwise, the product's operation may be affected.
- Before closing the maintenance door, check whether there is any object left inside the maintenance compartment, such as screws, tools, etc.
- It is recommended for users to use cable sheathing to protect the AC cable. If the cable sheathing is used, make sure it is positioned inside the maintenance compartment.

1.6 Disposal Safety

⚠ WARNING

Please scrap the product in accordance with relevant local regulations and standards to avoid property losses or casualties.

2 Product Description

2.1 System Introduction

The inverter is a transformerless 3-phase PV grid-connected inverter. As an integral component in the PV power system, the inverter is designed to convert the direct current power generated from the PV modules into grid-compatible AC current and to feed the AC current into the utility grid.

The intended usage of the inverter is illustrated in the following figure.

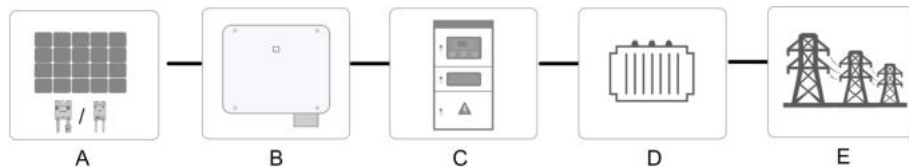

Figure 2-1 Inverter Application in PV Power System

WARNING

The inverter must not be connected to a PV string that requires positive or negative grounding.
Do not connect any local load between the inverter and the AC circuit breaker.

NOTICE

When designing the system, ensure that the operating ranges of all devices that are connected to the inverter meet the requirements of the inverter.
The PV modules in the system must comply with the IEC 61730-1 class II standard.
The inverter applies only to the scenarios described in this manual.

Item	Description	Note
	PV strings	Monocrystalline silicon, polycrystalline silicon and thin-film without grounding.
A	Optimizer (Optional)	Connected to the PV module by its input cable, the optimizer can track the module's maximum power and output the desired voltage through a DC/DC voltage conversion circuit.
	RSD (Optional)	The RSD equipment (rapid shutdown equipment) is connected to the PV module through input cables to enable

Item	Description	Note
		the rapid shutdown function. Up to two PV modules can be attached to one RSD.
B	Inverter	SG25CX-P2, SG30CX-P2, SG33CX-P2, SG36CX-P2, SG40CX-P2, SG50CX-P2
C	Grid connection cabinet	Includes devices such as AC circuit breaker, SPD, metering device.
D	Transformer	Raises the output voltage of the inverter to a level that meets the requirements of the grid.
E	Utility grid	The grid forms supported by the inverter are shown in the figure below.

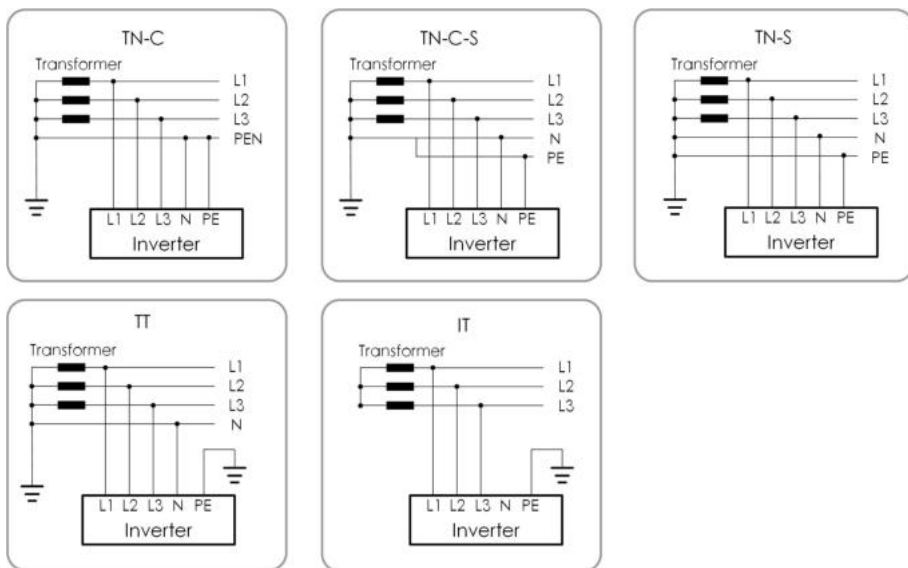

NOTICE

In a TT power grid, the N-PE voltage should be lower than 30 V. If the inverter is connected to the IT grid (i.e., no N line connection), there may be a risk of single-phase over/under-voltage and single-phase high/low voltage ride through.

Please refer to the optimizer user manual for details.



Please contact your local sales staff to confirm that the optimizer is available for sale in your territory.

Please refer to the RSD user manual for details.



Please contact your local sales staff to confirm that the RSD is available for sale in your territory.

2.2 Product Introduction

Model Description

The model description is as follows (take SG30CX-P2 as an example):

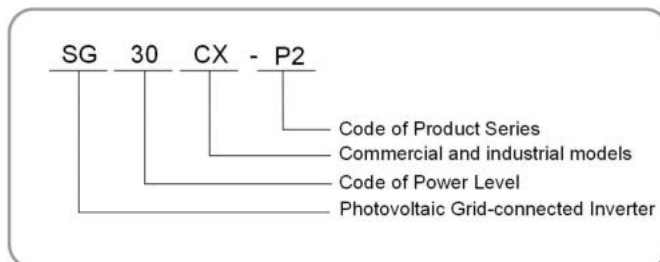

S320-G002

Appearance

The following figure shows the appearance of the inverter.

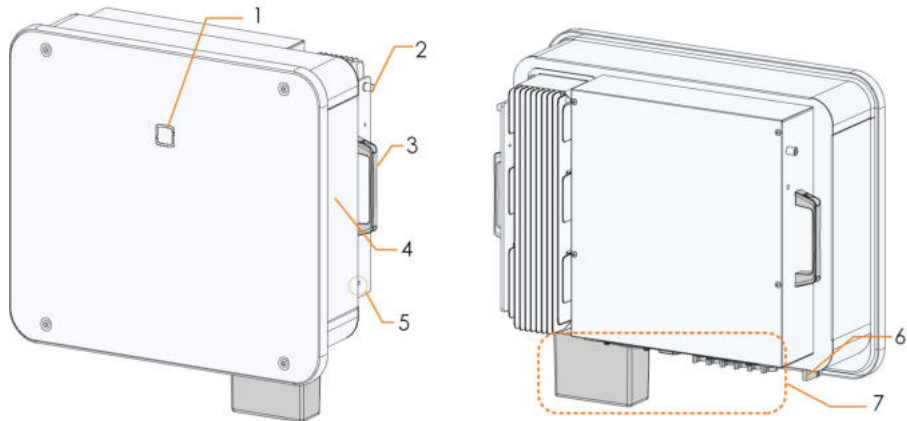

Figure 2-2 Appearance

The image shown here is for reference only. The actual product received may differ.

No.	Name	Description
1	LED indicator	To indicate the current working state of the inverter.
2	Mounting lugs	To hang the inverter onto the mounting-bracket.
3	Handles	To move the inverter.
4	Labels	To clearly identify the product, including Warning symbols,nameplate and QR code.
5	External protective grounding terminals	Use to ground the inverter.
6	DC switch	To safely disconnect the DC circuit whenever necessary.
7	Wiring area	DC switches, DC terminals, and communication terminals. For details, refer to 5.2 Terminal Description

Dimensions

The following figure shows the dimensions of the inverter.

















Figure 2-3 Product Dimensions(in mm)

Weight

Model	Dimensions (W*H*D)	Weight
SG25/30/33CX-P2		38 kg
SG36/40CX-P2	645*575*245 mm	40 kg
SG50CX-P2		41 kg

2.3 Symbols on Product

Symbol	Explanation
	Do not dispose of the inverter together with household waste.
	Read the user manual before maintenance!
	TÜV mark of conformity.
	Regulatory compliance mark.
	CE mark of conformity. EU/EEA Importer.
	RoHS labeling The product complies with the requirements of the applicable EU directives.

Symbol	Explanation
	UKCA mark of conformity.
	The inverter does not have a transformer.
	Disconnect the inverter from all the external power sources before maintenance!
	Burn danger due to the hot surface that may exceed 60°C.
	Danger to life due to high voltages! Only qualified personnel can open and service the inverter.
	Danger to life due to high voltages! Do not touch live parts for 15 minutes after disconnection from the power sources.
	*India standard mark for BIS
	CMim mark of conformity.
	External grounding point.



- The table shown here is for reference only. The actual product received may differ.
- Users may also attach other warning signs as per the requirements of the local standards or installation specifications.

*The BIS standard mark applies only to products sold in India.

2.4 LED Indicator

The LED indicator on the front of the inverter indicates the working state of the inverter.

Table 2-1 LED Indicator State Description

LED Color	State	Definition
 Blue	On	The device is connected to the grid and operating normally.
	Fast blink (Period: 0.2s)	The Bluetooth connection is established, and there is data communication. No system fault occurs.
	Slow blink (Period: 2s)	The device is in standby or startup state (not feeding power into the grid).
	Slow blink once, fast blink three times	The inverter is performing PID recovery.
 Red	On	A fault occurs and the device cannot connect to the grid.
	Blink	The Bluetooth connection is established, data communication in process, and a system fault occurs.
 Gray	OFF	Both the AC and DC sides are powered down.

⚠ WARNING

Voltage may still be present in AC side circuits after the indicator is off. Pay attention to the electricity safety when operating.

2.5 Circuit Diagram

The following figure shows the main circuit of the inverter.

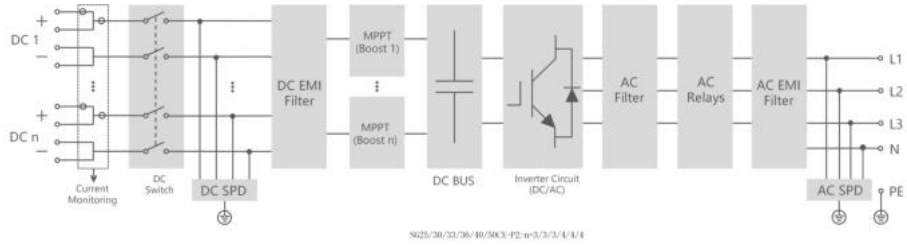

Figure 2-4 Circuit Diagram

- The DC Switch is used to safely disconnect the DC circuit.
- The MPPT is used to ensure a maximum power from PV arrays at different PV input conditions.
- The Inverter Circuit converts the DC power into AC power and feeds it to loads(if there are)or utility grid through the AC terminal.
- The protection circuit ensures the safe operation of the device and personal safety.

⚠ DANGER

If the lightning level exceeds the protection level of the product, surge protection and overvoltage protection may fail, resulting in electric shock and fatal injury!

2.6 Function Description

The inverter is equipped with the following functions:

Conversion Function

The inverter converts the DC current into grid-compatible AC current and feeds the AC current into the grid.

Data Storage

The inverter logs running information, error records, etc.

Parameter Configuration

The inverter provides various settable parameters. Users can set parameters via the App to meet the requirements and optimize the performance.

Communication Interface

The inverter is designed with standard RS485 communication interfaces and communication accessory port.

- The standard RS485 communication interfaces are used to establish communication with monitoring devices and to upload monitoring data to a monitoring background through communication cables.
- The communication accessory port is used to connect communication module manufactured by SUNGROW, and upload monitoring data through communication cables or wireless communication.

The inverter can be connected to communication devices via either of the two interfaces. When communication is established between the inverter and the communication devices, users can view inverter information or set inverter parameters, such as running parameter and protection parameter, through the iSolarCloud.



It is recommended to use the communication module from SUNGROW. Using a device from other companies may lead to communication failure or other unexpected damage.

Protection Function

The protective functions are integrated in the inverter, including anti-island protection, DC reversed polarity protection, AC short circuit protection, leakage current protection, etc.

Ripple Control

The inverter provides terminals (DRM) for connecting to a Ripple Control Receiver (RCR). After the connection, the grid dispatching center issues regulation instructions via dry contact (DI). The inverter can control power output according to the local preset instructions.

PID recovery



The PID function may not be applicable in some areas. Please consult SUNGROW for details.

The PID effect (Potential Induced Degradation) of PV modules will cause serious damage to generated output and yield, which can be avoided or recovered by PID recovery function.

- For positive voltage scheme, after the PID is enabled, the voltage to ground of all PV strings is greater than 0, and therefore the PV string-to-ground voltage is a positive value.

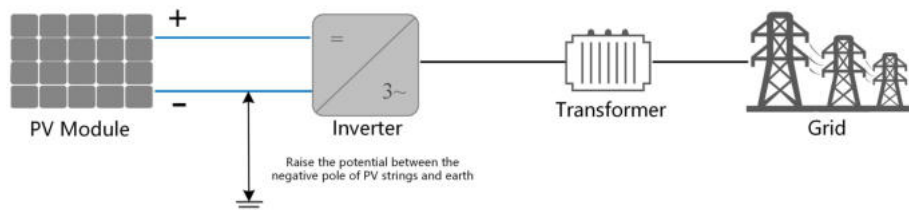

- For negative voltage scheme, after the PID is enabled, the voltage to ground of all PV strings is lower than 0, and therefore the PV string-to-ground voltage is a negative value.

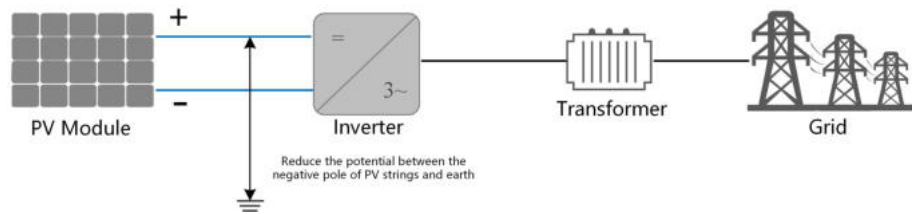

NOTICE

- **Before enabling the PID recovery function, make sure the voltage polarity of the PV modules to ground meets requirement. If there are any questions, contact the PV module manufacturer or read the corresponding user manual.**
- **PID recovery function and reactive power generation at night cannot be enabled at the same time.**
- **If the voltage scheme for the PID protection/recovery function does not meet the requirement of corresponding PV modules, the PID will not work as expected or even damage the PV modules.**
- **If the PID recovery function is enabled, it only works at night.**
- **When the inverter is in the PID recovery state (the indicator blinks blue once at long intervals and blinks at short intervals for three times), disable the PID recovery in the iSolarCloud App before manually powering on and maintaining the inverter.**

AFCI Function



The AFCI function may not be applicable in some areas. Please consult SUNGROW for details.

- **AFCI activation**
This function can be enabled to detect whether arc occurs in the DC circuit of the inverter.
- **AFCI self-test**
This function is intended to detect whether the AFCI function of the inverter is normal.
- **Clear AFCI Alarm**
When the inverter detects the AFCI alarm, it stops working. Clear the AFCI alarm so that the inverter can restart the detection.
- **Protection Coverage**
Two types of classifications are defined for AFCI protection, "F (Full coverage)" and "P (Partial coverage)". Full coverage protection ("F") is available for this inverter.
- **AFPE**
This inverter is equipped with a fully integrated AFPE, which is implemented within the inverter connected to the PV array and makes use of the enclosure and terminals of the inverter.
- **Method of Implementation**

Two implementation options are available for AFCI protection, "D" and "I". "D" represents "Distributed detection system", where the AFPE comprises more than one device. The devices may be standalone devices or partially integrated within the power conversion equipment (PCE). While "I" represents "PCE integrated device", where the AFPE is implemented within a PCE connected to the PV array and makes use of the enclosure and terminals of the PCE. "I" is adopted for this inverter.

- Reconnection Method

Three reconnection methods are available for this inverter:

1. Manual reconnection

Reconnection can only be performed manually after arc interruption. You can log in via local access to the iSolarCloud App, and choose **More**→ **Settings**→ **Operation Parameters**→ **AFCI Parameters**→ **Clear AFCI Alarm**; after clearing the fault alarm, restart the device.

2. Remote manual reconnection

Reconnection can be performed via remote access to the AFPE after interruption. You can log in to iSolarCloud remotely. Then, find the target plant and choose **Settings**; select the device, and choose **Advanced Settings**→ **Power Control**→ **Clear AFCI Alarm**. After clearing the fault alarm, restart the device.

3. Automatic reconnection

Reconnection can be performed automatically after arc interruption.

Rule: Upon detecting a real arc fault, the device will report a fault and shut down. Within the day, for the 1st to 4th arc fault alarm, the device will shut down for 10 minutes, then the alarm will be cleared and the device will restart; when the 5th or more arc fault is reported, the device will shut down and not resume operation on that day.

In the event of the 1st to 4th arc fault alarm, ARM is powered off and restarted, and the device can restart and reconnect to the grid normally, with the fault count reset to "0". When the 5th arc fault is detected, if ARM is powered off and restarted due to external environment factors, the device will report a fault and shut down, with the fault count changing to "1"; after 10 minutes, the fault alarm will be cleared and the device will restart. If ARM is not powered off when the 5th or more arc fault is reported, you need to clear the fault manually to get the device restarted and reconnected to the grid normally; in this case, the fault count will be reset to "0". Or you can wait for the fault to be cleared automatically the next day, in which case the fault count will change to "1". See "Manual reconnection" and "Remote manual reconnection" for instructions on how to clear the fault alarm manually.



The fault arc detection function meets the standard requirements, please test under the working conditions as required by the standard.

Optimizer Functions (Optional)

- Module-level MPPT

Increase the power generation of the PV system by continuously tracking the maximum power point of the PV module.

- **Module-level shutdown**
Quickly reduce module voltage.
- **Module-level monitoring**
The optimizer can monitor the performance of modules.
- **Module-level IV curve diagnosis**
The optimizer can scan the module IV curve and judge whether a module fault occurs. And in this case the inverter cannot perform string-level IV curve scan.
The Module-level IV curve diagnosis function can only be used on iSolarCloud Web. At most six modules can be selected in one round of Module-level IV curve diagnosis.

RSD Functions (Optional)

- **Module-level shutdown**
Quickly reduce module voltage.
- **Module-level monitoring**
The RSD can monitor the performance of modules.

PLC Function

The inverter's DC side is equipped with a built-in PLC communication module, which is specifically used for data communication with optimizers and RSDs used together with the inverter.



- By default, the PLC function of the inverter is disabled before factory delivery.
- For the SG25/30/33/36/40/50CX-P2 model, the PLC function must be enabled when used with optimizers or RSDs. For details, see [SP600S User Manual](#) or [SR20D-M User Manual](#).

3 Unpacking and Storage

3.1 Unpacking and Inspection

The product is thoroughly tested and strictly inspected before delivery. Nonetheless, damage may still occur during shipping. For this reason, please conduct a thorough inspection after receiving the product.

- Check the packing case for any visible damage.
- Check the scope of delivery for completeness according to the packing list.
- Check the inner contents for damage after unpacking.

Contact SUNGROW or the transport company in case of any damage or incompleteness, and provide photos to facilitate services.

Do not dispose of the original packing case. It is recommended to store the device in the original packing case when the product is decommissioned.

NOTICE

**After receiving the product, check whether the appearance and structural parts of the device are damaged, and check whether the packing list is consistent with the actual ordered product. If there are problems with the above inspection items, do not install the device and contact your distributor first. If the problem persists, contact SUNGROW in time.
If any tool is used for unpacking, be careful not to damage the product.**

3.2 Inverter Storage

Proper storage is required if the inverter is not installed immediately.

- Store the inverter in the original packing case with the desiccant inside.
- The storage temperature must be always between -40°C and $+70^{\circ}\text{C}$, and the storage relative humidity must be always between 0 and 95 %, non-condensing.
- In case of stacking storage, the number of stacking layers should never exceed the limit marked on the outer side of the packing case.
- The packing case should be upright.
- If the inverter needs to be transported again, pack it strictly before loading and transporting it.
- Do not store the inverter in places susceptible to direct sunlight, rain, and strong electric field.
- Do not place the inverter in places with items that may affect or damage the inverter.

- Store the inverter in a clean and dry place to prevent dust and water vapor from eroding.
- Do not store the inverter in places with corrosive substances or susceptible to rodents and insects.
- Carry out periodic inspections. Inspection shall be conducted at least once every six months. If any insect or rodent bites are found, replace the packaging materials in time.
- If the inverter has been stored for one year or longer, or has been mounted but remains non-operational for more than three months, it must be inspected and tested by qualified personnel before being put into operation.

NOTICE

Please store the inverter according to the storage requirements. Product damage caused by failure to meet the storage requirements is not covered by the warranty.

4 Mechanical Mounting

WARNING

Respect all local standards and requirements during mechanical installation.

4.1 Safety During Mounting

DANGER

Make sure there is no electrical connection before installation.
Before drilling, avoid the water and electricity wiring in the wall.

WARNING

For specific requirements for the installation environment, see [4.2.1 Installation Environment Requirements](#). In case the environment where the product is installed does not meet the requirements, SUNGROW shall not be held liable for any property damage arising therefrom.

CAUTION

Improper handling may cause personal injury!

- When moving the product, be aware of its weight and keep the balance to prevent it from tilting or falling.
- Wear proper protective equipment before performing operations on the product.
- The bottom terminals and interfaces of the product cannot directly contact the ground or other supports. The product cannot be directly placed on the ground.

NOTICE

During installation, ensure that no device in the system causes it hard for the DC switch and the AC circuit breaker to act or hinders maintenance personnel from operating.

If drilling is required during installation:

- Wear goggles and protective gloves when drilling holes.
- Make sure to avoid the water and electricity wiring in the wall before drilling.
- Protect the product from shavings and dust.

4.2 Location Requirements

To a large extent, a proper installation location ensures safe operation, service life, and performance of the inverter.

- The inverter with protection rating IP66 can be installed both indoors and outdoors.
- The inverter should be installed at a height that allows easy viewing of the LED indicator panel, as well as easy electrical connection, operation and maintenance.

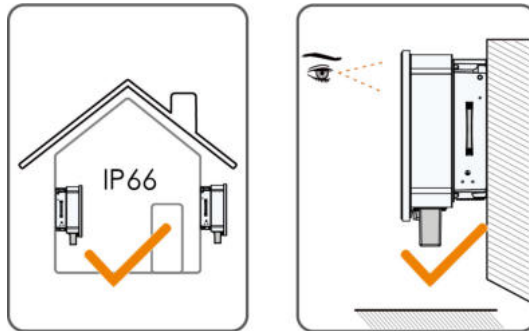

4.2.1 Installation Environment Requirements



- The inverter produces noise during operation, thus it is not recommended to install it in places for residential purpose. If this cannot be avoided, it is recommended to install the inverter in a place over 25 meters away from the residential area, or take noise mitigation measures.
- If the inverter is installed in a place with lush vegetation, weed on a regular basis. In addition, the ground beneath the inverter needs to undergo certain treatment, such as laying cement or gravel, etc. (an area of 3m×2.5m is recommended).
- Do not install the inverter in an environment with flammables, explosives, or smoke.
- Do not install the inverter in places prone to water leak, e.g., under the air-conditioner vent, the air vent, or the cable outlet window of the machine room, so as to prevent device damage or shortcircuit caused by intrusion of water.
- Do not install the inverter in a place with corrosives such as corrosive gas and organic solvent, etc.
- When the inverter is running, its surface may carry high voltages or get very hot. Do not touch it; otherwise, it may lead to burns or electric shocks.

- Do not install the inverter in a place that is easy to reach for people.
- The installation site must have solid ground, free of rubber-like soils (which cannot be effectively compacted) or weak soils, and should not be prone to subsidence. Also, avoid low-lying areas where water or snow may easily accumulate. Ensure the site is located above the highest recorded water level in the area.
- Do not install the inverter in a position that could be flooded.
- To prevent vegetation or water on the ground from impacting inverter operation, if the space above meets the designated requirements, elevate the inverter to an appropriate height.
- Install the inverter in a place with shelter, so as to prevent it from getting impacted by direct sunlight and severe weather (e.g. snow, rain, and lightning). The inverter will derate in high temperatures for self-protection. If installed in a place directly exposed to sunlight, as the temperature rises, the inverter may witness power reduction.
- Good heat dissipation is very important to the inverter. Please install the inverter in a ventilated environment.
- If the inverter needs to be installed in a closed or semi-closed environment, please install additional heat dissipation or ventilation devices. Furthermore, while the inverter is operating, ensure the indoor ambient temperature does not exceed the outdoor ambient temperature. A semi-closed environment refers to a special space where natural ventilation is limited and gas or heat may easily accumulate, although it is not fully enclosed on all six sides.
- Please consult SUNGROW before installing inverters outdoors in areas prone to salt damage, which mainly are coastal areas within 500 meters of the coast. The sedimentation amount of salt spray is correlated to the characteristics of the seawater, sea winds, precipitation, air humidity, topography, and forest coverage in the adjacent sea areas, and there are substantial differences between different coastal areas.
- To ensure device safety and service life, avoid using this product in highly polluted environments containing substances such as sulfur or halogens.
- The inverter is strictly prohibited from being installed in environments with vibration or strong electromagnetic fields (including strong common-mode interference). A strong magnetic field environment refers to one where the magnetic field strength exceeds 30 A/m. The aforementioned environments may cause the product to malfunction.
- In dusty environments such as places full of dust, smoke, or floc, particles may cling to the device's air outlet or heat sink, thus impacting its heat dissipation performance or even getting it damaged. Therefore, do not install the inverter in dusty environments. If the inverter has to be installed in such environments, please clean its fans and heat sink on a regular basis to ensure a good heat dissipation performance.
- The average temperature approximately 1 m around the inverter should be taken as its ambient operating temperature. The temperature and humidity should meet the requirements below:

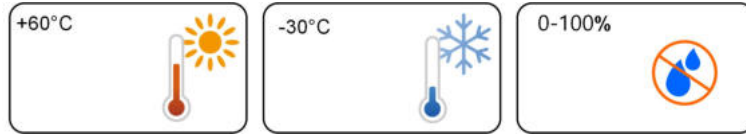

- For installed inverters that remain non-operational for an extended period, follow these requirements:
 - Seal all unused DC terminals with the plugs supplied with the inverter.
 - If the inverter is installed in a dusty or sandy environment, add protective covers at the air inlet and outlet to prevent dust accumulation that could obstruct airflow and affect fan operation. Remove the protective covers before putting the inverter into service.

4.2.2 Carrier Requirements

The mounting structure where the inverter is installed must comply with local/national standards and guidelines. Ensure that the installation surface is solid enough to bear four times the weight of the inverter and is suitable for the dimensions of the inverter (e.g. cement walls, plasterboard walls, etc.).

Do not install the inverter on a carrier that may vibrate in resonance, so as to avoid making bigger noise.

Installation on combustible building materials is strictly prohibited. Suitable mounting surfaces include:

Non-combustible wall surfaces: Concrete, fire-resistant gypsum board, brick wall, etc. Non-combustible roof structures: Color-Coated corrugated steel roofing sheets, precast concrete slabs, fiber-reinforced cement boards, etc.

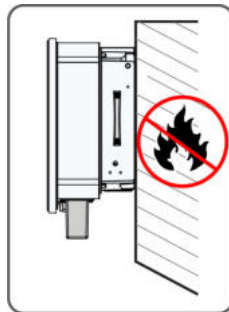

4.2.3 Angle Requirements

Install the inverter vertically or at the maximum allowable rear tilt angle. Do not install the inverter horizontally, forward, excessively backward, sideways, or upside down.

Inverters in floating plants cannot be installed at a back tilt.

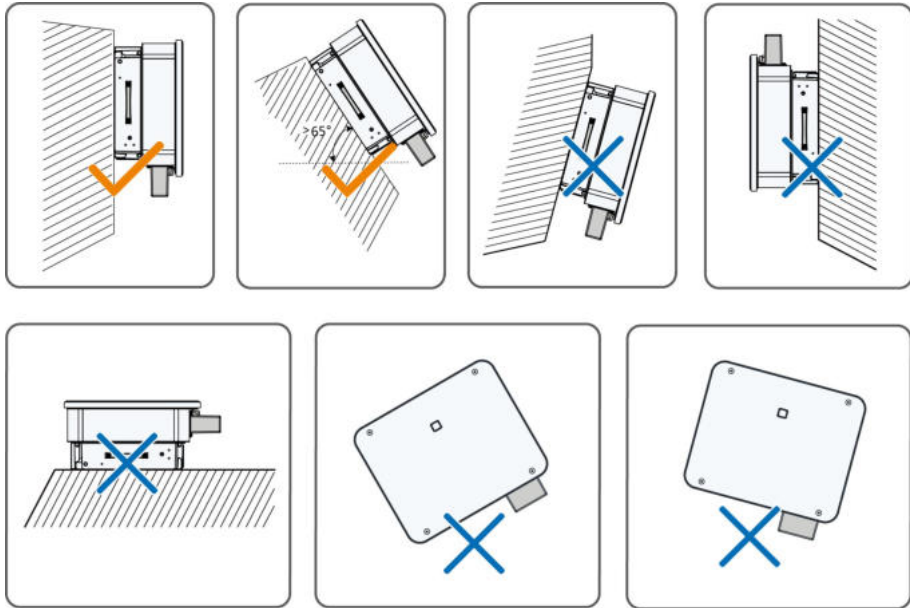

tilting backwards installation requirements

In case the installation site is a level surface, mount the inverter to the horizontal-mounting bracket to meet the mounting angle requirements, as shown in the figure below.

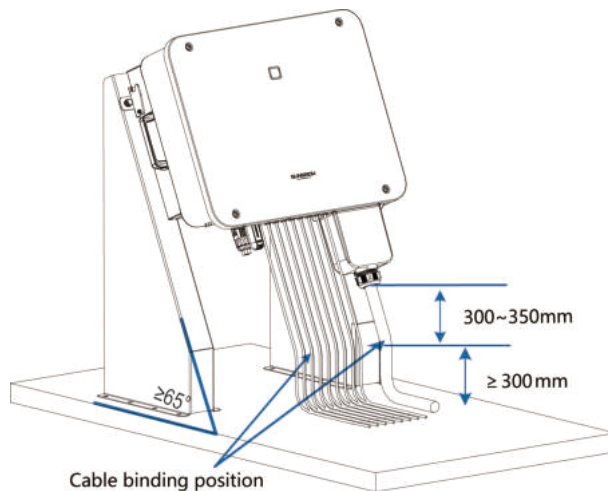

Take the following items into account when designing the bracket scheme:

- Consider onsite climate conditions and take anti-snow and anti-rain measures if necessary.
- Ensure that the waterproof connectors are at least 300mm higher than the ground surface.
- Bind the cables at the positions 300~350mm away from the DC connector, AC waterproof terminal, and communication waterproof terminal.
- The various waterproof terminals should be tightened with the torque specified in this manual to ensure that they are securely sealed.

4.2.4 Clearance Requirements

Reserve enough clearance around the inverter to ensure sufficient space for heat dissipation.

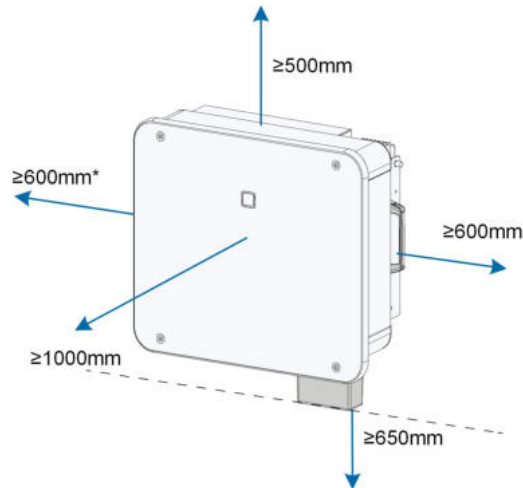

*When this distance is less than the distance shown, lift the inverter off the stand or wall before maintaining fans.

The distance from the bottom of the inverter to the ground is determined according to the bending radius of the selected AC cable and the installation environment, and the following requirements should be met:

- The distance from the bottom of the inverter to the ground should be $\geq 650\text{mm}$.
- The AC cable should be connected to the AC terminal vertically, and the length of the vertical cable should be $\geq 200\text{mm}$.

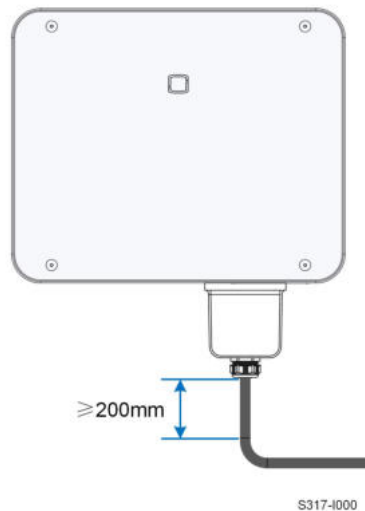

Contact the AC cable manufacturer for any questions.

In case of multiple inverters, reserve specific clearance between the inverters.



Goggles

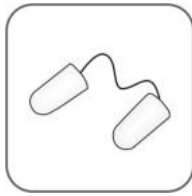

Earplugs

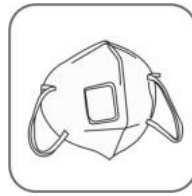

Dust mask



Safety gloves



Safety shoes



Utility knife



Anti-static wrist strap



Marker



Level



Hammer drill
($\phi 12$)



Rubber mallet



Phillips
screwdriver
(M4, M5, M6)



Open-end wrench
(16 mm, 60 mm)



Socket wrench set
(M8)



Wire cutter



Wire stripper



Hydraulic plier



Heat gun



Crimping tool



Connector wrench

4–6mm²

Multimeter
≥ 1100 Vdc



Vacuum cleaner

4.4 Moving the Inverter

Before installation, remove the inverter from the packing case and move it to the installation site. Follow the instructions below as you move the inverter:

- Always be aware of the weight of the inverter.
- Prevent the inverter from tilting or dropping.

Lift and move the inverter to the destination by using the side handles and bottom edge.

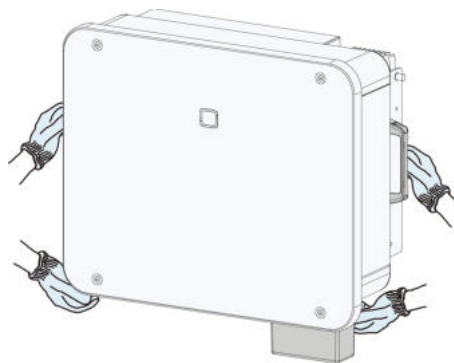

⚠ CAUTION

Improper handling may cause personal injury!

- Arrange an appropriate number of personnel to carry the inverter according to its weight, and installation personnel should wear protective equipment such as anti-impact shoes and gloves.
- Attention must be paid to the center of gravity of the inverter to avoid tilting during handling.
- Placing the inverter directly on a hard ground may cause damage to its metal enclosure. Protective materials such as sponge pad or foam cushion should be placed underneath the inverter.
- Move the inverter by holding the handles on it. Do not move the inverter by holding the terminals.

4.5 Installing Mounting-bracket

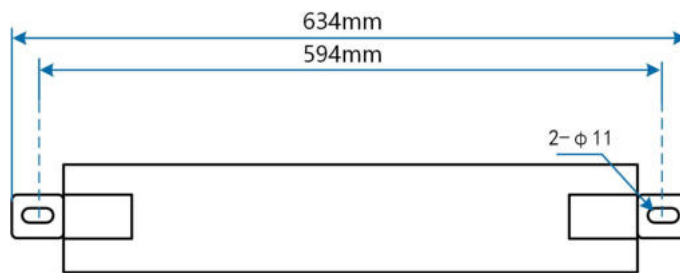
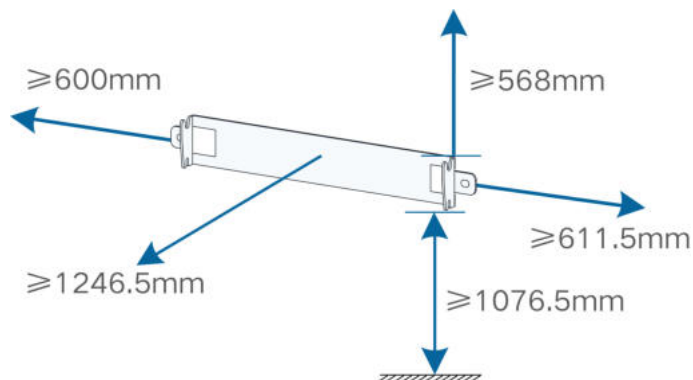

Figure 4-1 Dimensions of Mounting-bracket

To meet the space requirements of the inverter, please reserve sufficient space when installing the mounting bracket.



4.5.1 Bracket-Mounted Installation

Prerequisite

Tool preparation

Name	Specification
Marker	—
Level	-
Hammer drill	Bit: $\phi 12$
Wrench	Inner diameter: 16mm

Material preparation

Name	Quantity	Specification	Source
Bolt assembly	2	M10	Included in the delivery scope
Steel u-channel	2	-	Not included in the delivery scope

Step 1 Mark and drill holes in one steel u-channel according to the dimensions shown in the figure below. Two steel u-channels should be spaced 180 mm - 260 mm apart.



Step 2 Secure the mounting-bracket to the steel u-channel with bolts.

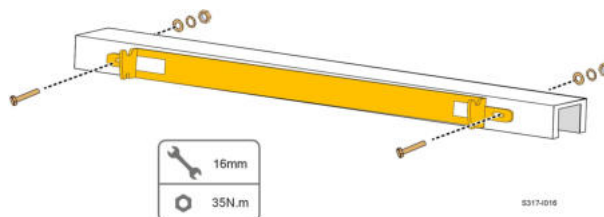

--End

4.5.2 Wall-Mounted Installation

Prerequisite

Tool preparation

Name	Specification
Maker	—
Level	-
Hammer drill	Bit: $\varnothing 12$
Wrench	Inner diameter: 16mm

Material preparation

Name	Quantity	Specification	Source
Expansion bolt	2	M10	Not included in the delivery scope

Step 1 Place the mounting-bracket at the installation place, adjust the angle with a level, and mark the location of the drilled holes.

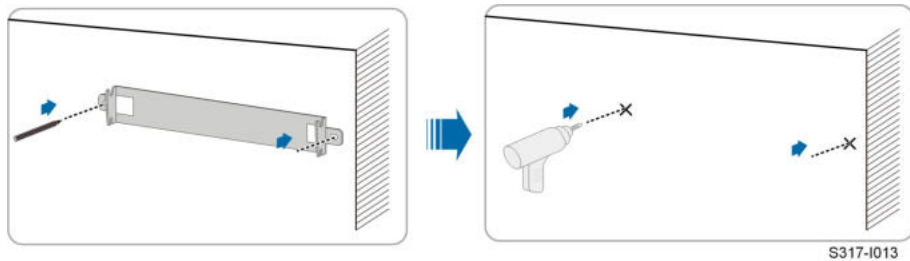

Step 2 Drill holes with a hammer drill. Clean up the holes, stuff the expansion bolts into the holes, and fix them with a rubber mallet. Use a wrench to tighten the nut to fix the end of the bolt, take off the nut, spring washer and flat washer for spare.

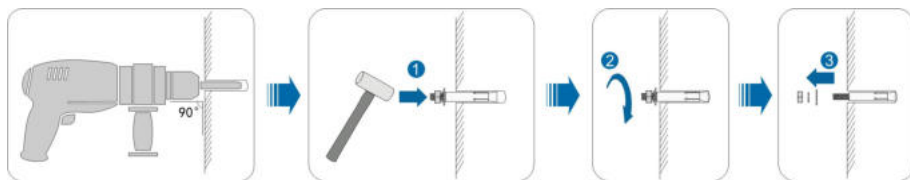

After removing the nut, spring washer, and flat washer, level the front of the expansion tube with the wall. Otherwise, the mounting brackets will not stay steady on the wall.

Step 3 Secure the mounting-bracket with expansion bolts.

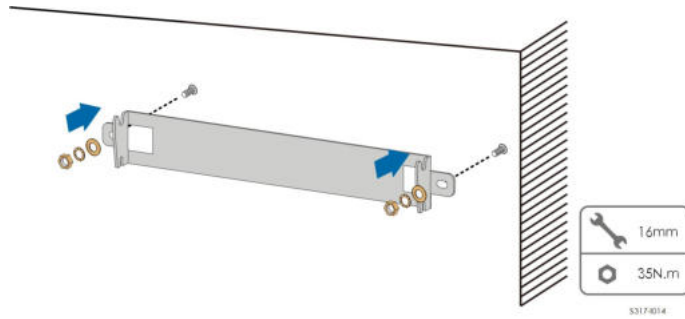

--End

4.5.3 Pole Installation

Prerequisite

Tool preparation

Name	Specification
Marker	—
Level	-
Hammer drill*	Bit: $\varnothing 12$
Wrench	Inner diameter: 16mm

*Check if tools of other specifications are needed according to the bolts of the matching clamps.

Material preparation

Name	Quantity	Specification	Source
Bolt assembly	2	M10	Included in the delivery scope
Bolt assembly	4	M10	Not included in the delivery scope
Steel u-channel	2	-	Not included in the delivery scope
Clamp	2	According to the pole specification	Not included in the delivery scope

Step 1 Erect and stabilize the pole at the installation site.



Please skip this step if the inverter is to be installed on a concrete pole, PV bracket, etc. through pole-mounting.

Step 2 Mark and drill holes in steel u-channels according to the dimensions shown in the figure below. Two steel u-channels should be spaced 180 mm - 260 mm apart.

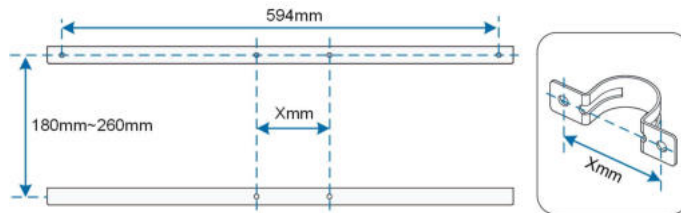

Step 3 Secure the mounting-bracket to the steel u-channels with bolts.

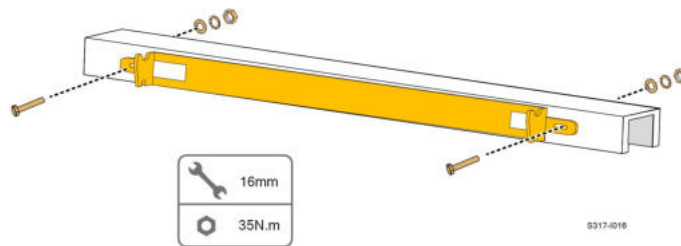

Step 4 Secure the steel u-channels to the pole with bolts and clamps.

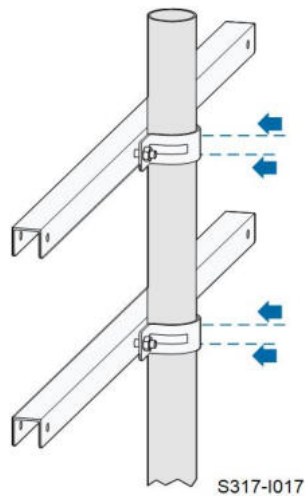

--End

4.6 Installing the Inverter

Prerequisite

Tool preparation

Name	Specification
Phillips screwdriver	M5

Material preparation

Name	Quantity	Specification	Source
Cross screw	2	M5×16	Included in the delivery scope

Step 1 Take out the inverter from the packing case.

Step 2 Lift the inverter onto the mounting-bracket and make sure the mounting ears fit well into the grooves of the mounting-bracket.

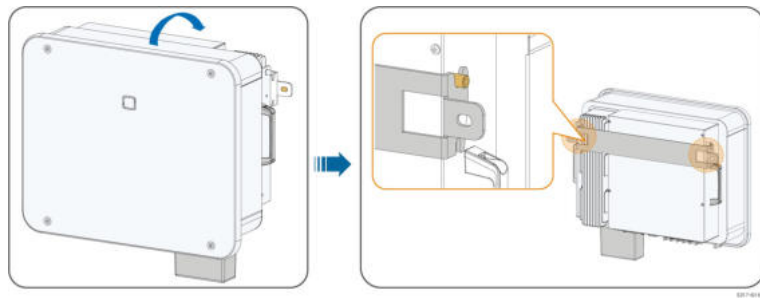

Step 3 Fix the inverter with screws.

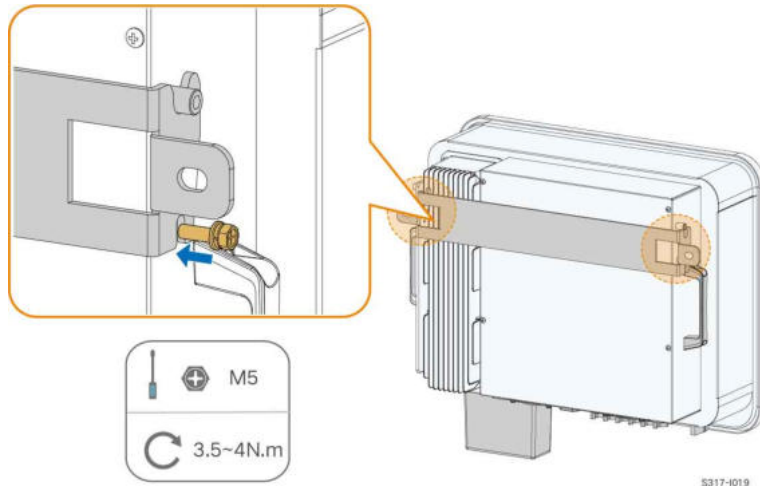

--End

4.7 Installing Optimizer(Optional)

If optimizers are selected for the system, install the optimizers by referring to the [SP600S Quick Installation Guide](#).

4.8 Installing the RSD (Optional)

If RSDs are selected for the system, install the RSDs by referring to the [SR20D-M Quick Installation Guide](#).

5 Electrical Connection

5.1 Safety Instructions

DANGER

The PV string will generate lethal high voltage when exposed to sunlight.

- Operators must wear proper personal protective equipment during electrical connections.
- Must ensure that cables are voltage-free with a measuring instrument before touching DC cables.
- Respect all safety instructions listed in relevant documents about PV strings.

DANGER

- Before electrical connections, please make sure that the inverter switch and all switches connected to the inverter are set to "OFF", otherwise electric shock may occur!
- Ensure that the inverter is undamaged and all cables are voltage free before performing electrical work.
- Do not close the AC circuit breaker until the electrical connection is completed.

WARNING

Do not damage the ground conductor. Do not operate the product in the absence of a properly installed ground conductor. Otherwise, it may cause personal injury or product damage.

Please use measuring devices with an appropriate range. Overvoltage can damage the measuring device and cause personal injury.

Damage to the product caused by incorrect wiring is not covered by the warranty.

- Electrical connection must be performed by professionals.
- Operators must wear proper personal protective equipment during electrical connections.
- All cables used in the PV generation system must be firmly attached, properly insulated, and adequately dimensioned. Cables used shall comply with the requirements of local laws and regulations.
- The factors that affect cable selection include rated current, cable type, routing mode, ambient temperature, and maximum expected line loss.

NOTICE

All electrical connections must comply with local and national/regional electrical standards.

- Cables used by the user shall comply with the requirements of local laws and regulations.
- Only with the permission of the national/regional grid department, the inverter can be connected to the grid.
- Requires external protection device.
- Requires external multipole interruption device for current carrying wires disconnection.
- Requires an external residual current device (DR), suitable for protection against electric shock, in accordance with the ABNT NBR 5410 standard.
- It is expressly recommended to use rapid shutdown methods, systems or devices on the d.c.circuit. that guarantee safety in firefighting situations.
- The installation of this equipment must comply with current technical standards for photovoltaic electrical installation (NBR 16690) and fire risk management in photovoltaic systems (IEC 63226).
- This equipment is compatible with external independent rapid shutdown devices.

NOTICE

- Install the external protective grounding cable first when performing electrical connection and remove the external protective grounding cable last when removing the inverter.
- Keep the AC output cable and the DC input cable close to each other during electrical connection.
- Comply with the safety instructions related to PV strings and the regulations related to the utility grid.

NOTICE

- After being crimped, the OT terminal must wrap the wires completely, and the wires must contact the OT terminal closely.
- When using a heat gun, protect the device from being scorched.
- Keep the PV+ cable and PV- cable close to each other when connecting DC input cables.
- Before connecting a power cable (such as the AC cable, the DC cable, etc.), confirm that the label and identifier on the power cable are correct.
- When laying out communication cables, separate them from power cables and keep them away from strong interference sources to prevent communication interruption.
- All vacant terminals must be covered with waterproof covers to prevent affecting the protection performance.
- Ensure that AC output cables are firmly connected. Failing to do so may cause inverter malfunction or damage to its AC connectors.
- When the wiring is completed, seal the gap at the cable inlet and outlet holes with fireproof/waterproof materials such as fireproof mud to prevent foreign matter or moisture from entering and affecting the long-term normal operation of the inverter.



The cable colors in figures in this manual are for reference only. Please select cables according to local cable standards.

5.2 Terminal Description

All electrical terminals are located at the bottom of the inverter.

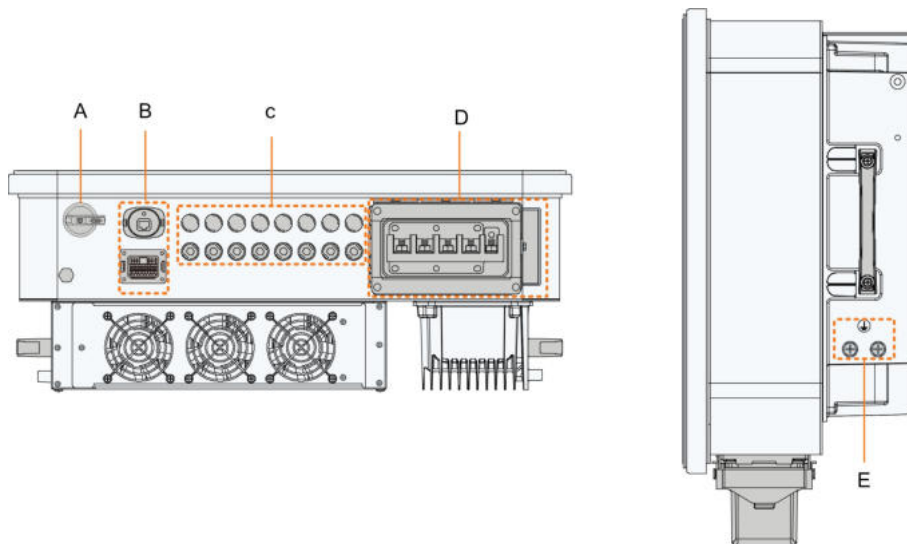

Figure 5-1 Terminal Description

* The image shown here is for reference only. The actual product received may differ.

Item	Terminal	Mark	Note
A	DC Switch	DC SWITCH	Used to switch on and off the DC input.
B	Communication terminal	COM1	For communication module connection.
		COM2	DI, DRM, DO, RS485, Smart Energy Meter
C	PV terminals	PV1,PV2, PV3, PV4, PV5, PV6	6 pairs of terminals(SG25/30/33CX-P2)
		PV1,PV2, PV3, PV4, PV5, PV6, PV7, PV8	8 pairs of terminals(SG36/40/50CX-P2)
D	AC wiring terminal	AC	Used for AC output cable connection.
E	External protective grounding terminal		Used for reliable grounding of the inverter 2, use at least one of them to ground the inverter.

Table 5-1 The label of COM2 terminal

DI		DRM		DO	RS485		Meter	
DI	DI	C	D4/8	D2/6	COM	B1	B1	B2
PGN D	PGN D	R	D3/7	D1/5	NO	A1	A1	A2

Table 5-2 The label description of COM2 terminal

No.	Label	Description
1	DI	emergency stop dry contact
2	DRM	<ul style="list-style-type: none"> "AU"/"NZ": Demand response enabling device (DRED) "DE": Ripple Control Receiver (RCR)
3	DO	fault output dry contact
4	RS485 (A1, B1) (1)	<ul style="list-style-type: none"> Connect to the Logger, so as to implement data exchange with PC or other monitoring devices. Enable the communication between inverters in parallel.
5	Meter (A2, B2) (1)	Connect to the Smart Energy Meter.

(1) When the inverter is connected to a third-party monitoring device, please confirm which communication interface is used, and whether it will cause loss of certain functions of the inverter.

5.3 Electrical Connection Overview

Connecting the inverter to the PV system requires connecting the inverter to the protective grounding point, to the grid, and to the PV strings.

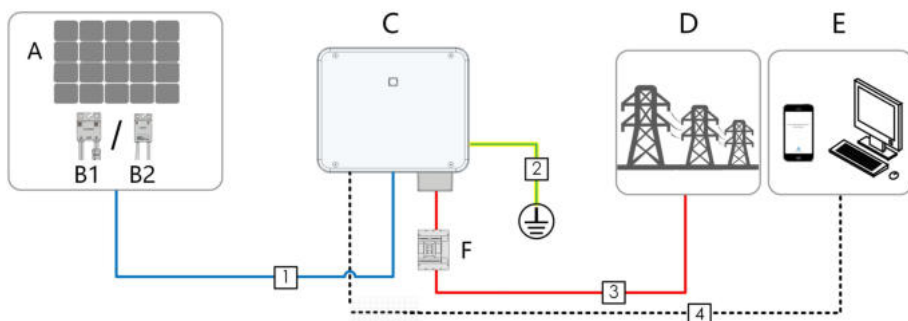

No.	Cable	Type	Specification	
			Cable Diameter(mm)	Cross-sectional Area(mm ²)
4	Communication cable	Shielded twisted pair		0.5~1
		CAT 5E outdoor shielded network cable	5.3 ~ 7	/

*A copper to aluminum adapter terminal is required when an aluminum cable is used. For details, refer to [Aluminum Cable Requirements](#).

** The specifications are valid only when the phase wire and PE wire use the same material. If otherwise, ensure that the cross section of the PE wire produces a conductance equivalent to that of the 16mm² in the table.

Table 5-4 PE wire requirements

PE wire cross section	Note
S/2 (S: Phase wire cross-section S)	The specifications are valid only when the phase wire and PE wire use the same material. If otherwise, ensure that the cross section of the PE wire produces a conductance equivalent to that of the wire specified in the table.

Other sizes of grounding cables that meet local standards and safety regulations can also be used for grounding connections. But SUNGROW shall not be held liable for any damage caused.

5.4 Crimp OT/DT terminal

Crimp OT/DT terminal

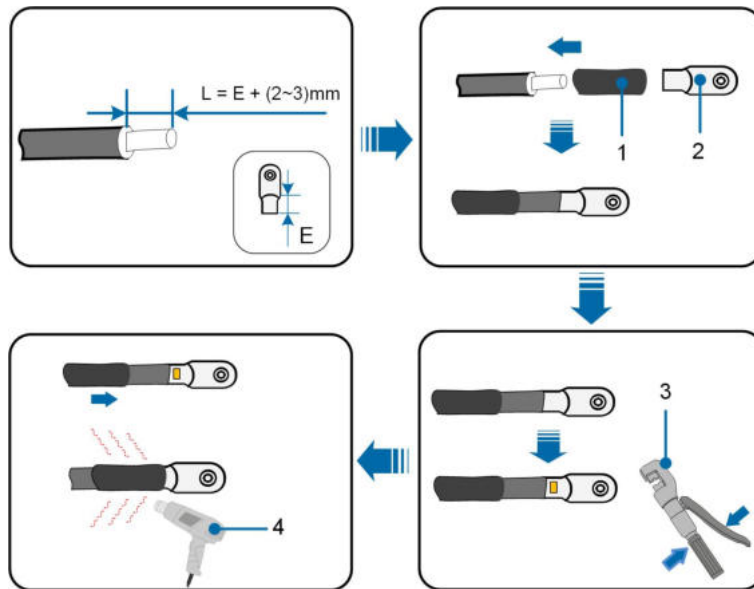

1. Heat shrink tubing

2. OT/DT terminal

3. Hydraulic pliers

4. Heat gun

Aluminum Cable Requirements

If an Aluminum cable is selected, use a copper to Aluminum adapter terminal to avoid direct contact between the copper bar and the Aluminum cable.

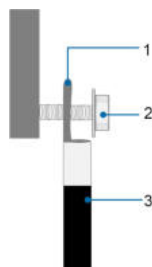

Figure 5-2 Aluminum Cable Connection

1. Copper to Aluminum adapter terminal

2. Flange nut

3. Aluminum cable

NOTICE

Ensure that the selected terminal can directly contact with the copper bar. If there are any problems, contact the terminal manufacturer.

Ensure that the copper bar is not in direct contact with the aluminum wire.

Otherwise, electrochemical corrosion may occur, impairing the reliability of electrical connection.

5.5 External Protective Grounding Connection

⚠ DANGER

- There are large currents during the inverter's operation. If the inverter is powered on and put into operation without being grounded, it may lead to electric shock hazards or failures of major protective functions such as surge protection. Therefore, before powering on the inverter, make sure it has been reliably grounded; otherwise, damages caused therefrom will not be covered by warranty.
- When performing electrical connections of the inverter, give the highest priority to grounding. Be sure to carry out the grounding connection first.

⚠ WARNING

- Since the inverter is not equipped with a transformer, neither the negative electrode nor the positive electrode of the PV string can be grounded. Otherwise, the inverter will not operate normally.
- Connect the grounding terminal to the external protective grounding point before AC cable connection, PV string connection, and communication cable connection.
- The external protective grounding point provides a reliable ground connection. Do not use an improper grounding conductor for grounding. Otherwise, it may cause product damage or personal injury.
- Depending on Local Rules, please also ground the PV panel subconstruction to the same common grounding point (PE Bar) in addition to local lightning protection rules.

⚠ WARNING

The external protective grounding terminal must meet at least one of the following requirements.

- The cross-sectional area of the grounding cable is not less than 10 mm² for copper wire or 16 mm² for aluminum wire. It is recommended that both the external protective grounding terminal and the AC side grounding terminal be reliably grounded.
- If the cross-sectional area of the grounding cable is less than 10 mm² for copper wire or 16 mm² for aluminum wire, ensure that both the external protective grounding terminal and the AC side grounding terminal are reliably grounded.

The grounding connection can be made by other means if they are in accordance with the local standards and regulations, and SUNGROW shall not be held liable for the possible consequences.

5.5.1 External Protective Grounding Requirements

All non-current carrying metal parts and device enclosures in the PV power system should be grounded, for example, brackets of PV modules and inverter enclosure.

When there is only one inverter in the PV system, connect the external protective grounding cable to a nearby grounding point.

When there are multiple inverters in the PV system, connect the external protective grounding terminals of all inverters and the grounding points of the PV module brackets to ensure equipotential connections to ground cables (according to the onsite conditions).

5.5.2 Connection Procedure

Step 1 Prepare the cable and OT/DT terminal, refer to [Crimp OT/DT terminal](#).

Step 2 Remove the screw on the grounding terminal and fasten the cable with a screwdriver.

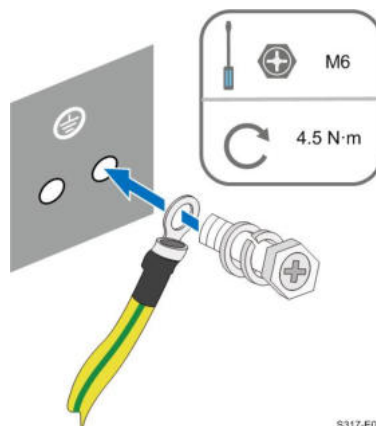

Step 3 Apply paint to the grounding terminal to ensure corrosion resistance.



The grounding screws have been anchored to the side of the inverter before delivery, and do not need to be prepared. There are two grounding terminals. Use one of them to ground the inverter.

--End

5.6 AC Cable Connection

5.6.1 AC Side Requirements



Only with the permission of the local grid department, the inverter can be connected to the grid.

Before connecting the inverter to the grid, ensure the grid voltage and frequency comply with requirements, for which, refer to "**Technical Data**". Otherwise, contact the electric power company for help.

AC Circuit Breaker

An independent circuit breaker or fuse should be installed on the output side of the inverter to ensure safe disconnection from the grid.

Inverter	Recommended Rated Voltage	Recommended Rated Current
SG25CX-P2	400V	63 A
SG30CX-P2	400V	63 A
SG33CX-P2	400V	80 A
SG36CX-P2	400V	80 A
SG40CX-P2	400V	100 A
SG50CX-P2	400V	125 A

WARNING

AC circuit breakers should be installed on the output side of the inverter and the grid side to ensure safe disconnection from the grid.

- Determine whether an AC circuit breaker with greater overcurrent capacity is required based on actual conditions.
- Do not connect any local load between the inverter and the AC circuit breaker.
- Multiple inverters cannot share one AC circuit breaker.

Residual Current Monitoring Device

With an integrated universal current-sensitive residual current monitoring unit included, the inverter will disconnect immediately from the mains power once a fault current with a value exceeding the limit is detected.

However if an external residual current device (RCD) (type A is recommended) is mandatory, the switch must be triggered at the residual current. RCD of other specifications can also be used according to local standard. The recommended residual current is as follows.

Inverter	Recommended Residual Current
SG25CX-P2	300 mA
SG30CX-P2	300 mA
SG33CX-P2	330 mA
SG36CX-P2	360 mA
SG40CX-P2	400 mA
SG50CX-P2	500 mA

Multiple Inverters in Parallel Connection

If multiple inverters are connected in parallel to the grid, ensure that the total number of parallel inverters does not exceed 25.

Maximum Number of Optimizers/RSDs

If SUNGROW Logger1000 is used, a maximum of 4900 optimizers or RSDs can be connected.

Please connect to two RS485 ports when over 3000 optimizers or RSDs for single Logger1000.

For comprehensive guidelines on optimizer connections, refer to Section **2.5: Configuration Principles** in the Optimizer User Manual, available at: [SP600S User Manual](#).

For comprehensive guidelines on optimizer connections, refer to Section **2.4: Configuration Principles** in the RSD User Manual, available at: [SR20D-M User Manual](#).

5.6.2 Requirements for OT/DT Terminal

OT / DT terminals (not included in the delivery scope) are required for fixing AC cables to the terminal block. Purchase the OT / DT terminals according to the following requirements.

OT / DT Terminals of Phase Wire

- Specification: M8

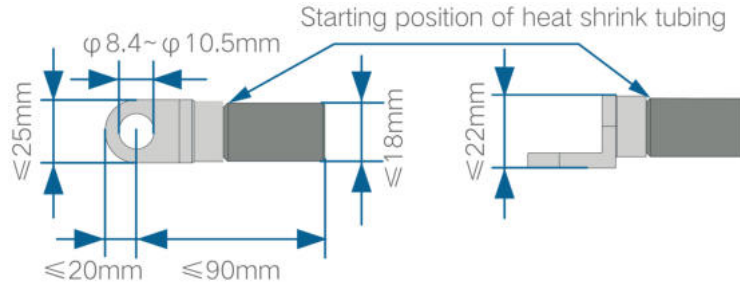

Figure 5-3 Specifications of the Crimped OT/DT Terminal

OT / DT Terminal of PE Wire

- Specification: M8

5.6.3 Connection Procedure

Step 1 Disconnect the AC-side circuit breaker and prevent it from inadvertent reconnection.

Step 2 Take out the AC junction box and loosen the swivel nut. After removing the seals, select one or more appropriate seals for use in combination according to the cable outer diameter, by referring to the table below. Lead the cable through the swivel nut, seal, and junction box successively.

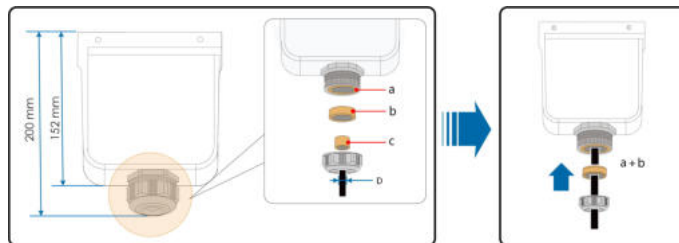

Outer diameter D(mm)	Seals
18 ~ 24	a+b+c
24 ~ 30	a+b
30 ~ 38	a

Step 3 Make the cable and crimp OT/DT terminal.

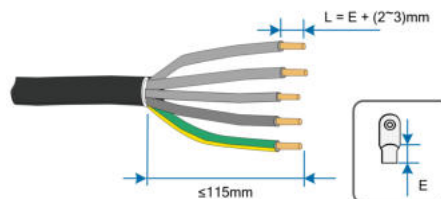

Step 4 Remove the AC protective cap.

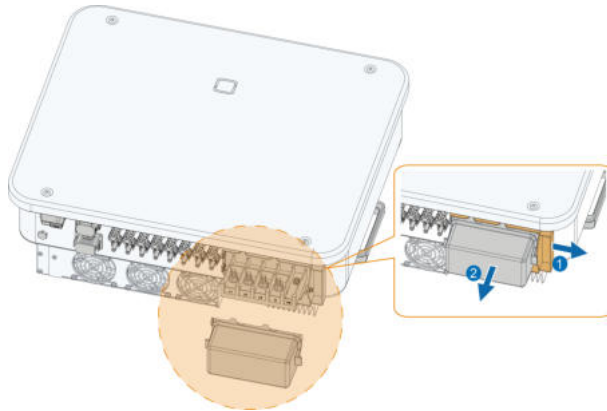

Step 5 Secure the wires to corresponding terminals. Gently pull the cable backwards to ensure firm connection.

NOTICE

Observe the terminal layout on the block. Do not connect the phase wires to "PE" terminal or "N" terminal. Otherwise, unrecoverable damage to the inverter may follow.

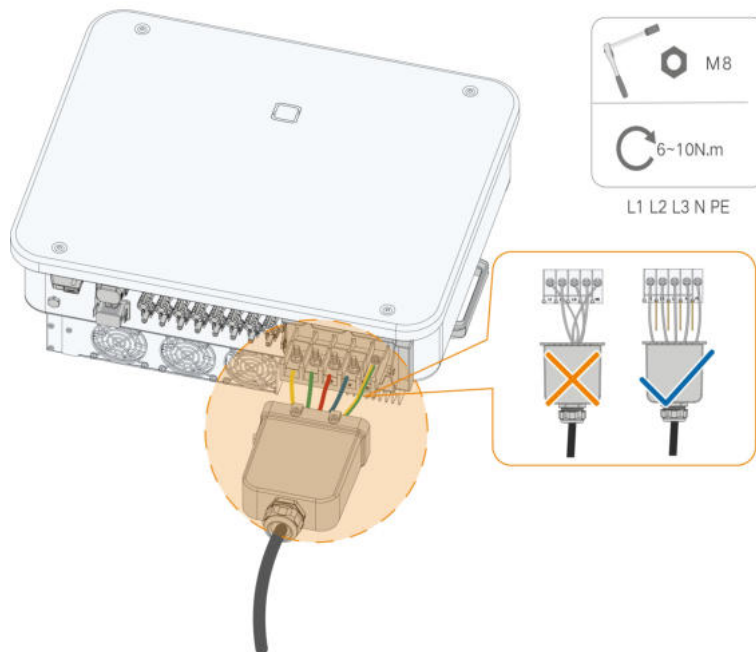

Ensure that the depth L of the socket used is not less than 18 mm.

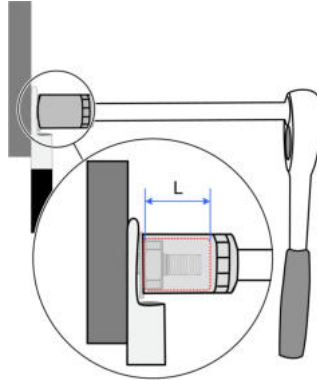

Step 6 Secure the junction box.

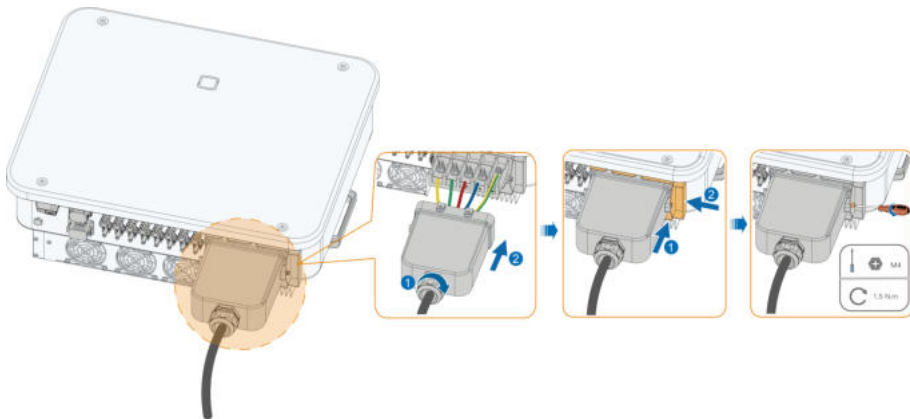

NOTICE

Ensure that the junction box is properly assembled. Failure to do so may affect the waterproof performance of the AC side, and the loss caused by this is not covered by the warranty.

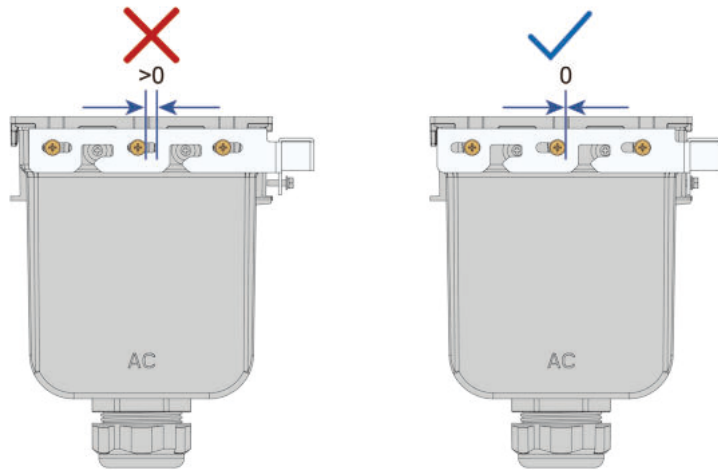

Step 7 Gently pull the cable backwards to ensure firm connection, and fasten the swivel nut clockwise.

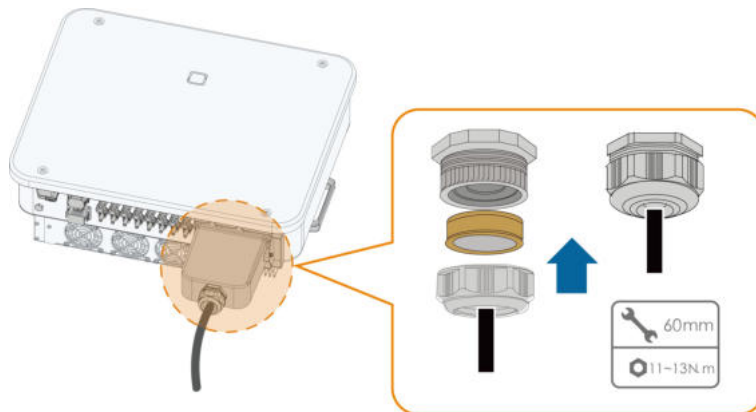

--End

5.7 DC Cable Connection

⚠ DANGER

The PV string will generate lethal high voltage when exposed to sunlight.

- Respect all safety instructions listed in relevant documents about PV strings.

⚠ WARNING

- **Make sure the PV array is well insulated to ground before connecting it to the inverter.**
- **Make sure the maximum DC voltage and the maximum short circuit current of any string never exceed inverter permitted values specified in "Technical Data".**
- **Check the positive and negative polarity of the PV strings, and connect the PV connectors to corresponding terminals only after ensuring polarity correctness.**
- **During the installation and operation of the inverter, please ensure that the positive or negative electrodes of PV strings do not short-circuit to the ground. Otherwise, an AC or DC short-circuit may occur, resulting in equipment damage. The damage caused by this is not covered by the warranty.**
- **Electric arc or contactor over-temperature may occur if the DC connectors are not firmly in place, and the loss caused is not covered by the warranty.**
- **If the DC input cables are reversely connected or the positive and negative terminals of different MPPT are shorted to ground at the same time, while the DC switch is in the "ON" position, do not operate immediately. Otherwise, the inverter may be damaged. Please turn the DC switch to "OFF" and remove the DC connector to adjust the polarity of the strings when the string current is lower than 0.5 A.**
- **Use the DC connectors supplied with the product for DC cable connection. Using incompatible DC connectors may result in serious consequences, and the device damage is not covered under warranty.**
- **Inverters do not support full parallel connection of strings (Full parallel connection refers to a connection method in that strings are connected in parallel and then connected to the inverter separately).**
- **Do not connect one PV string to multiple inverters. Otherwise, the inverters may be damaged.**

NOTICE

The following requirements about PV string connection must be met. Otherwise, it may cause irreversible damage to the inverter, which is not covered by the warranty.

- **Mixed use of PV modules of different brands or models in one MPPT circuit, or PV modules of different orientation or inclination in a string may not damage inverter, but will cause system bad performance!**
- **The inverter enters standby state when the input voltage ranges between 1,000 V and 1,100 V. The inverter returns to running state once the voltage returns to the MPPT operating voltage range, namely, 160 V to 1,000 V.**

NOTICE

Note the following items when laying cables on site:

- The axial tension on PV connectors must not exceed 80 N. Avoid axial cable stress on the connector for a long time during field wiring.
- Radial stress or torque must not be generated on PV connectors. It may cause the connector waterproof failure and reduce connector reliability.
- Leave at least 50 mm of slack to avoid the external force generated by the cable bending affecting the waterproof performance.
- Refer to the specifications provided by the cable manufacturer for the minimum cable bending radius. If the required bending radius is less than 50 mm, reserve a bending radius of 50 mm. If the required bending radius is greater than 50 mm, reserve the required minimum bending radius during wiring.

5.7.1 PV Input Configuration

- As shown in the figure below, the inverter is provided with multiple PV inputs, and each PV input is designed with an MPP tracker.
- Each PV input operates independently and has its own MPPT. In this way, string structures of each PV input may differ from each other, including PV module type, number of PV modules in each string, angle of tilt, and installation orientation.
- A maximum of two PV strings can be connected to an MPPT controller. For the best use of PV power, the type, quantity, tilt, and orientation of PV modules connected to the same MPPT shall be the same.

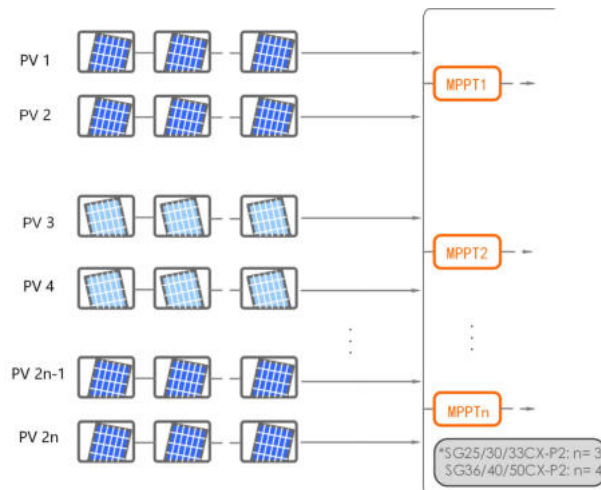

Figure 5-4 PV Input Configuration

Prior to connecting the inverter to PV inputs, the specifications in the following table should be met:

Open-circuit Voltage Limit	Max. Current for Input Connector
1100 V	30 A

5.7.2 Assembling PV Connectors

Prerequisite

⚠ DANGER

High voltage may be present in the inverter!

- Ensure all cables are voltage-free before performing electrical operations.
- Do not connect the AC circuit breaker before finishing electrical connection.



SUNGROW provides corresponding PV connectors in the scope of delivery for quick connection of PV inputs. To ensure IP66 protection, use only the supplied connector or the connector with the same ingress of protection.

Step 1 Strip the insulation from each DC cable by 8 mm ~ 10 mm.

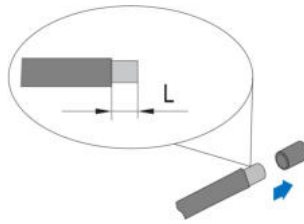

Step 2 Assemble the cable ends with the crimping pliers.

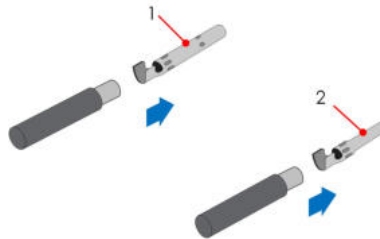

1: Positive crimp contact

2: Negative crimp contact

Step 3 Lead the cable through the cable gland, and insert the crimp contact into the insulator until it snaps into place. Gently pull the cable backward to ensure firm connection.

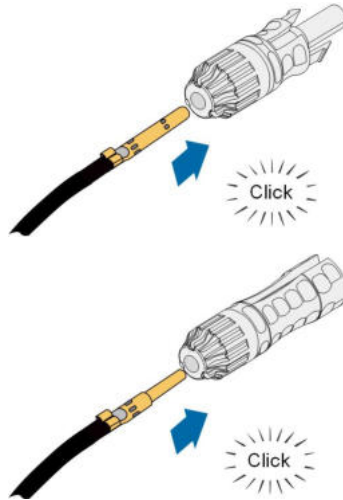

Step 4 Tighten the cable gland and the insulator.

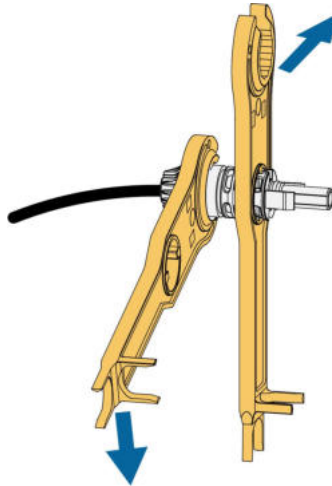

Step 5 Check for polarity correctness.

NOTICE

If the PV polarity is reversed, the inverter will be in a fault or alarm state and will not operate normally.

--End

5.7.3 Installing PV Connector

Step 1 Ensure that the DC switch is in "OFF" position. Otherwise, manually turn it to "OFF".

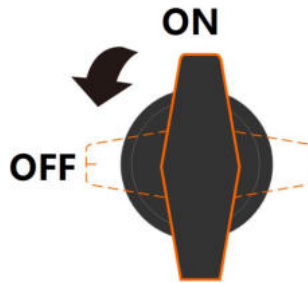

Step 2 Check the cable connection of the PV string for polarity correctness and ensure that the open circuit voltage in any case does not exceed the inverter input limit of 1,100 V.

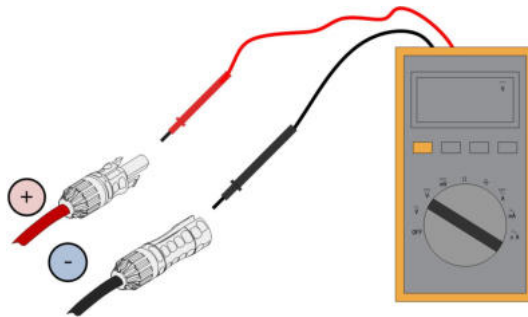

NOTICE

The multimeter must have a DC voltage range of at least 1100 V. If the voltage is a negative value, the DC input polarity is incorrect. Please correct the DC input polarity. If the voltage is greater than 1100 V, too many PV modules are configured to the same string. Please remove some PV modules.

Step 3 Optimizer/RSD Wiring (Optional)



The wiring procedures for optimizers and RSDs are largely similar. The following steps illustrate the process for the optimizer. For more detailed instructions, refer to their Quick Installation Guide.

- a. Connect the PV+ and PV- of the optimizer to the positive and negative terminals in the junction box of the PV module respectively.

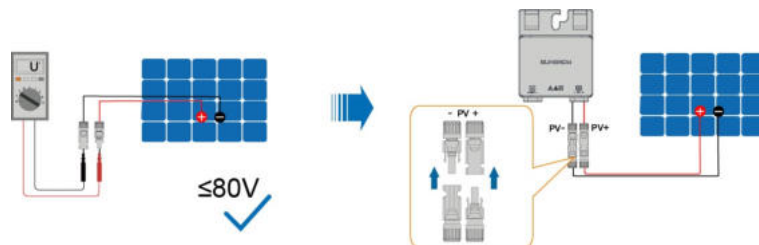

⚠ WARNING

- Before installing the optimizer, confirm the specifications of the PV module, and use a multimeter to test the voltage at the terminals of the PV cables to be connected to the optimizer's input terminals. Connect the optimizer only after confirming that the voltage is below 80V (Connect the RSD only after confirming that the voltage across two series-connected PV modules is below 125 V), otherwise, the device may be damaged.
- Do not connect the PV module to the OUT+ and OUT- of the optimizer. Otherwise, the optimizer or PV module will be damaged, and the loss is not covered by the warranty.

- b. Connect the positive probe of a multimeter to OUT+ of the optimizer, and the negative probe of the multimeter to OUT- of the optimizer to check whether the optimizer is faulty. If typical value of output voltage is 1V, no fault occurs to the optimizer.

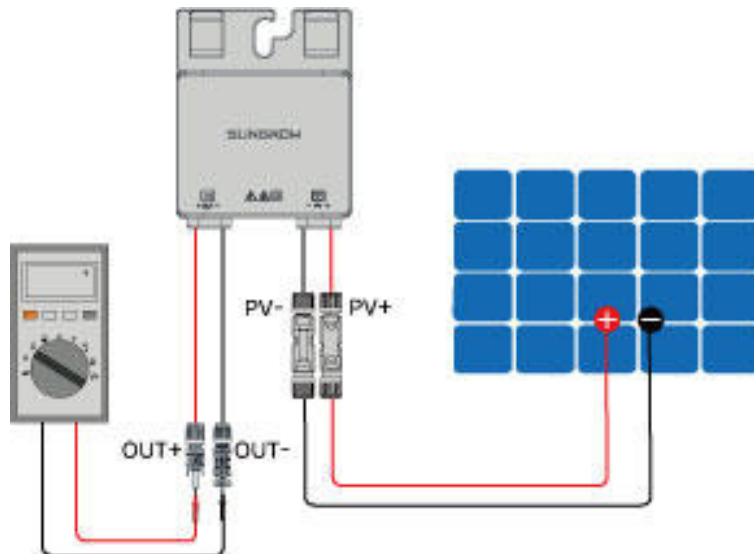

NOTICE

1. Use a multimeter to measure the output voltage of each optimizer after wiring.
2. Considering the effect of the accuracy of the multimeter on the actual measurement on site, the optimizer can function normally as long as the output voltage falls in the range of 0.9V - 1.1V.
3. If the output voltage is less than 0.9 V, check the following items:
 - Check whether the sunlight is sufficient.
 - Check whether the input side of the optimizer is connected to the PV module.
 - If the fault is not caused by foregoing reasons and still persists, please replace the optimizer.
4. If the output voltage is greater than 1.1 V, the optimizer fails. Please replace the optimizer.
5. If no voltage is detected, replace the optimizer or component.

⚠ WARNING

If you do not check the optimizer output voltages and confirm the string has been wired properly in this step, in case of something abnormal, you may have to check the whole wiring again, where rework is required.

- c. When connecting multiple optimizers, connect OUT- of the first optimizer to OUT + of the second optimizer, and so on. Use a multimeter to measure the optimizer voltage. If typical value of output voltage is $1V*N$ (N is the number of optimizers), no fault occurs to the system.

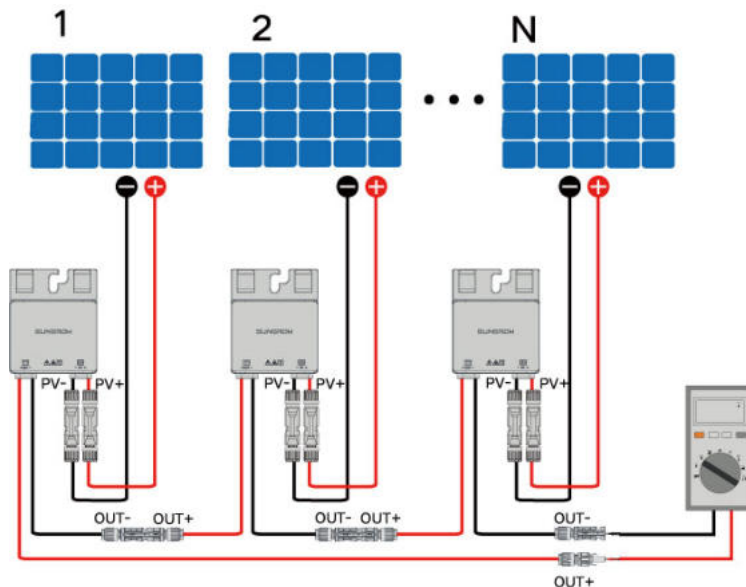

NOTICE

Whether connecting OUT+ of the first optimizer to OUT- of the second optimizer or connecting OUT- of the first optimizer to OUT+ of the second optimizer is dependent on the polarity of the extension cable that is connected to the inverter on site.

⚠ WARNING

After wiring, be sure to check and confirm that the string output voltage is in normal range. Otherwise, it may lead to optimizer damages and wiring rework.

- d. Connect OUT+ of the first optimizer and OUT- of the last optimizer to the PV input terminals of the inverter.

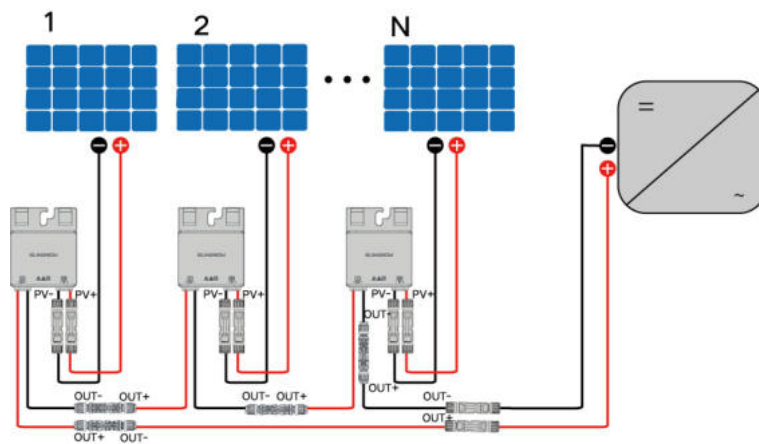
**⚠ WARNING**

If each PV module is equipped with an optimizer, the total power of PV modules in a PV input shall not exceed the maximum input power of a single PV input of the inverter.

⚠ CAUTION

Please refer to terminal configuration description from inverter user manual if the inverter strings are not fully connected. Otherwise, it may cause power loss.

NOTICE

- **Branch-connector connection on the input side of the inverter is not supported by the optimizer.**
- **Do not coil the optimizer's extension cable when wiring, given that the communication quality may decline if the extension cable is too long.**

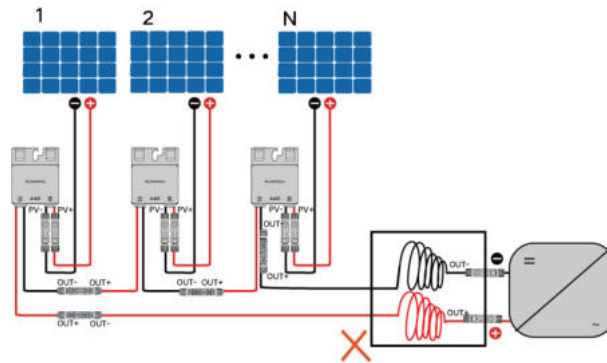

Step 4 Connect the PV connectors to corresponding terminals until there is an audible click.

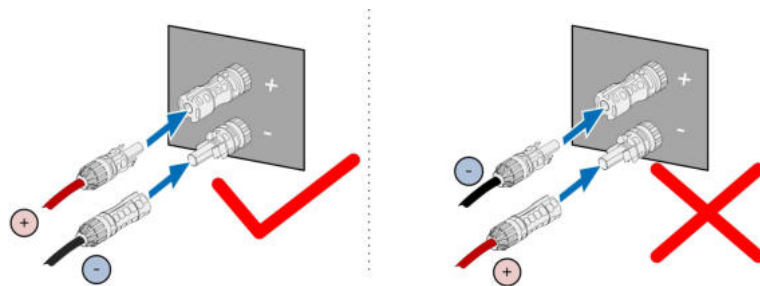

Step 5 Follow the foregoing steps to connect PV connectors of other PV strings.

Step 6 Seal any unused PV terminal with a terminal cap.

--End

NOTICE

- **After the PV string is connected to the input terminal on the inverter, please turn on the corresponding DC switch.**
- **Only when the DC switch is set to "ON", the DC Type II is able to provide effective protection against electrical surges.**

5.8 Communication Connection

5.8.1 Wireless Communication Module Connection (optional)

Install the wireless communication module to the communication interface with a silk screen of COM1 at the bottom of the inverter.

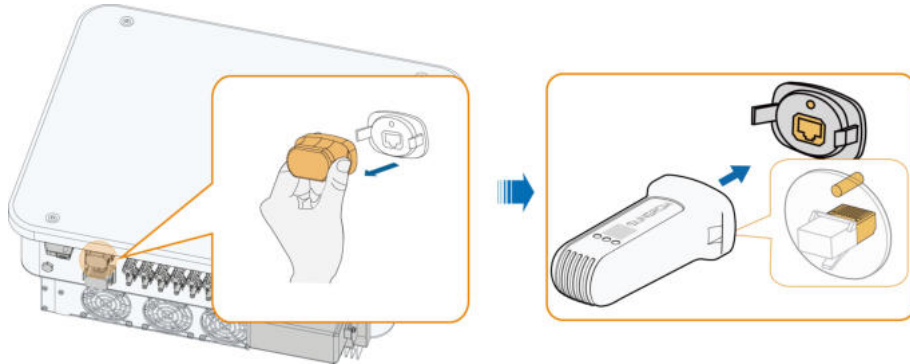

*The image shown here is for reference only. The actual product you receive may differ.

NOTICE

Once the communication module is in use, do not connect the inverter to a data logger at the same time via RS485. Please contact SUNGROW for any further queries.



For details on module installation and configuration, refer to the manual delivered together with the module.

5.8.2 WiNet-S/WiNet-S2 Connection (optional)

The WiNet-S / WiNet-S2 module supports Ethernet communication and WLAN communication. It is not recommended to use both communication methods at the same time.

For details, see the quick guide for the WiNet-S/WiNet-S2 module. Scan the following QR code for the quick guide.



WiNet-S



WiNet-S2

5.8.2.1 Ethernet Communication

Step 1 (Optional) Strip the insulation layer of the communication cable with an Ethernet wire stripper, and lead the corresponding signal cables out. Insert the stripped communication cable into the RJ45 plug in the correct order, and crimp it with a crimper.

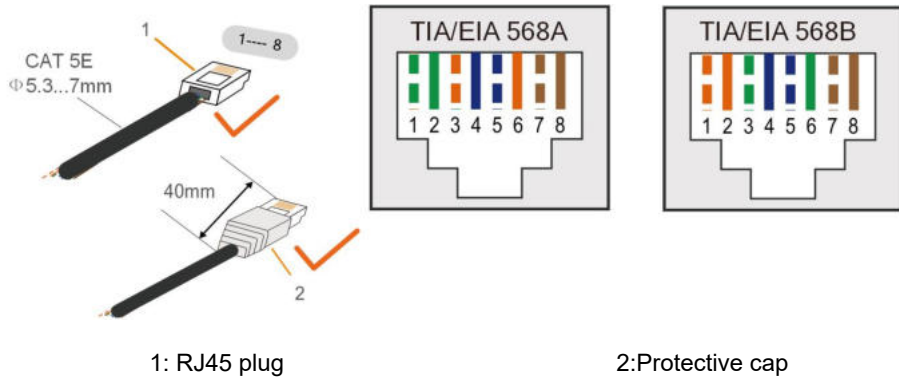

i Skip this step if a standard network cable with RJ45 plug is prepared.

Step 2 Unscrew the swivel nut from the communication module and take out the inner sealing ring.

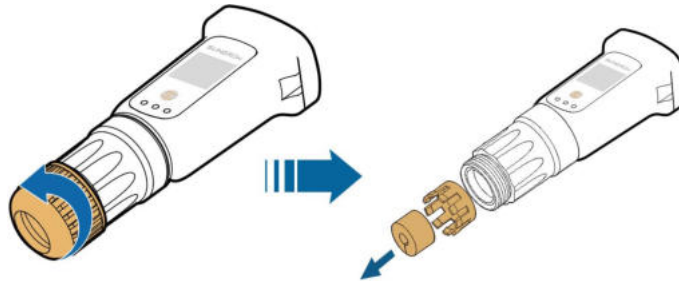

Step 3 Unscrew the housing from the communication module.

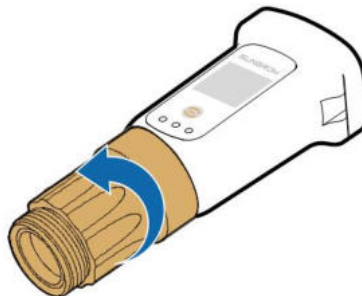

Step 4 Thread the network cable through the swivel nut and gasket. Afterwards, route the cable into the opening of the sealing. Finally, insert the cable through the housing.

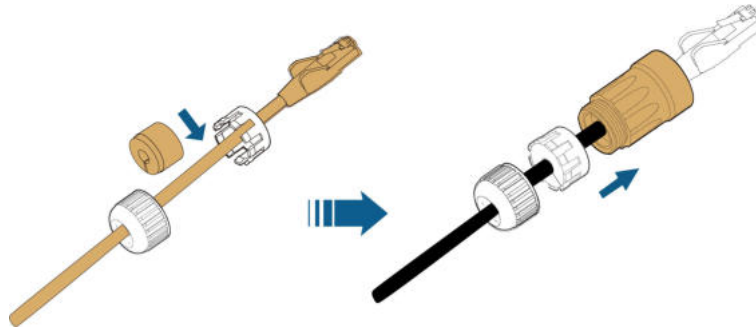

Step 5 Insert the RJ45 plug into the front plug connector until there is an audible click and tighten the housing. Install the gasket and fasten the swivel nut.

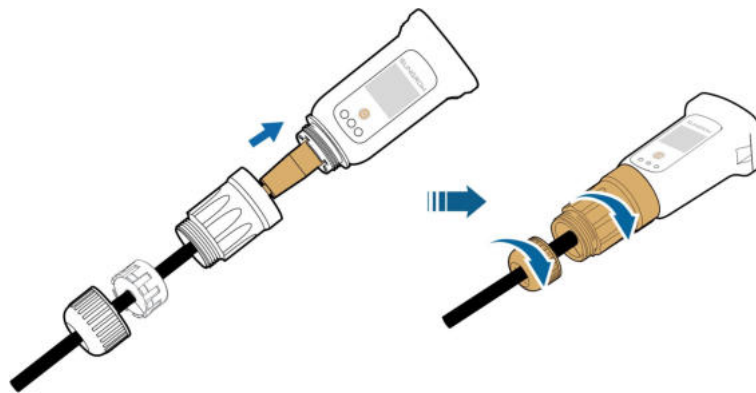

Step 6 Remove the waterproof lid from the **COM1** terminal and install WiNet-S/WiNet-S2.

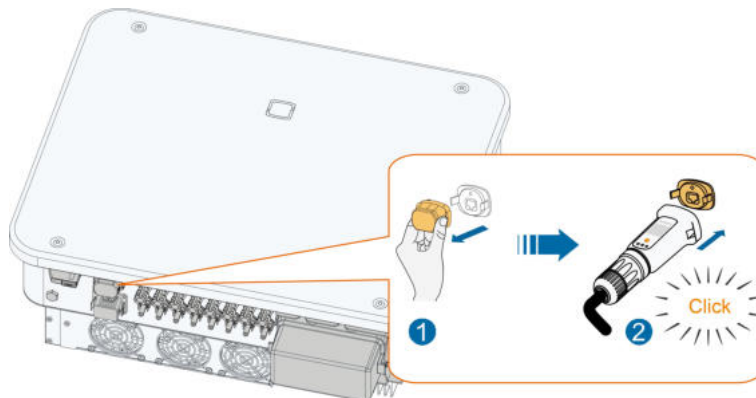

Step 7 Slightly shake it by hand to determine whether it is installed firmly.

--End

5.8.2.2 WLAN Communication

Step 1 Remove the waterproof lid from the **COM1** terminal.

Step 2 Install the module. Slightly shake it by hand to determine whether it is installed firmly, as shown below.

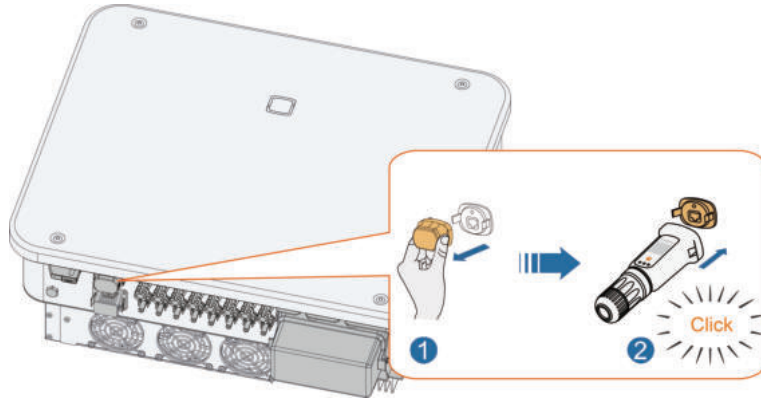

Step 3 Refer to the guide delivered with the module for the set-up.

--End

5.8.3 RS485 Connection

Where there is only one inverter, the RS485 can be connected to an external device for the communication, as shown in the following figure.

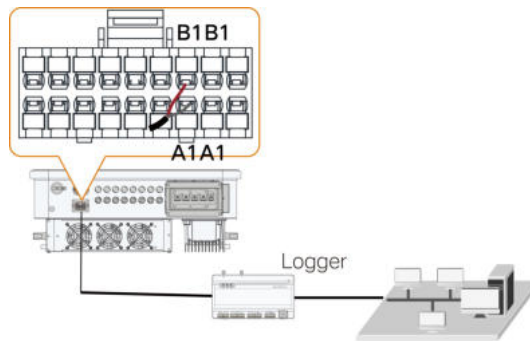

In case of multiple inverters, all the inverters can be connected via RS485 cables in the daisy chain manner, as shown in the following figure.

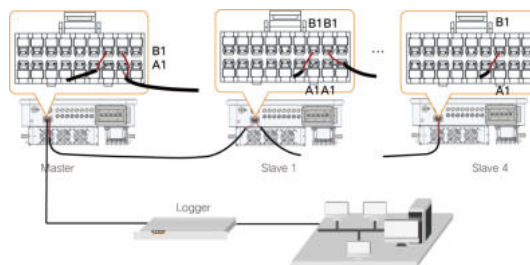

5.8.3.1 Assembling the COM Connector

Prerequisite



SUNGROW cooperates with multiple suppliers on communication connectors, so there may be cases where two types of communication connectors are received. Both communication connectors are wired in the same way, and the actual product received shall prevail.

Step 1 Unscrew the swivel nut from the connector.

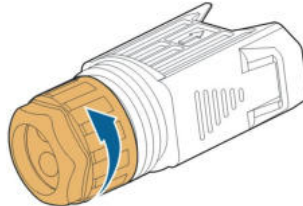

Step 2 Take out the terminal block.

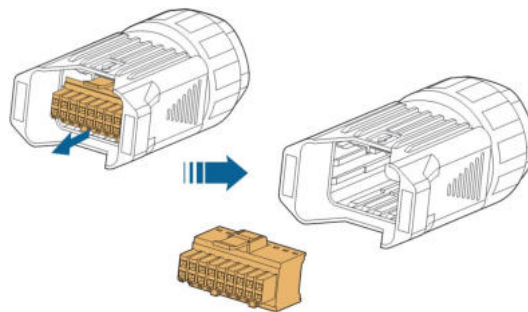

Step 3 Remove the seal and lead the cable through the cable gland.

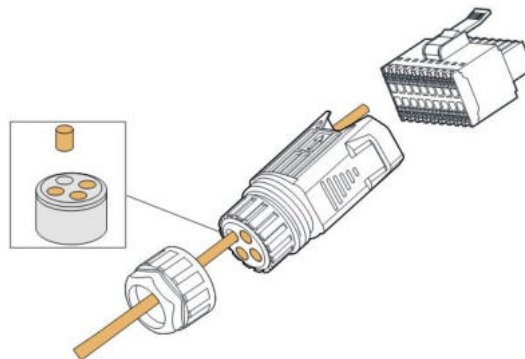

Step 4 Remove the cable jacket and strip the wire insulation.

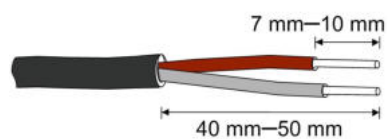

Step 5 Plug the wires into the **RS485** terminal according the labels on the bottom of the inverter.

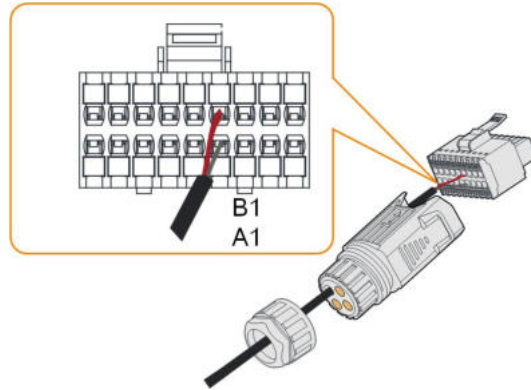

Step 6 Pull the wires outward to check whether they are firmly installed.

Step 7 Insert the terminal block into the connector until it snaps into place with an audible click.

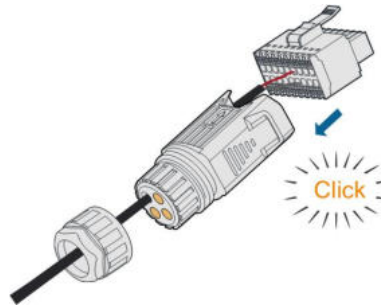

Step 8 Fasten the swivel nut.

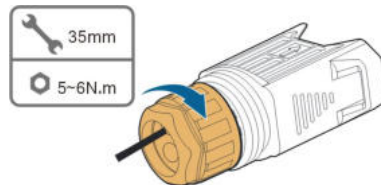

--End

5.8.3.2 Installing the COM Connector

Step 1 Remove the waterproof lid from the **COM2** terminal.

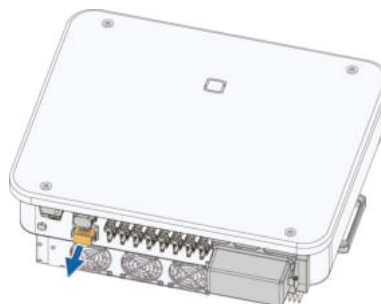

Step 2 Insert the COM connector into **COM2** terminal on the bottom of the inverter until there is an audible click.

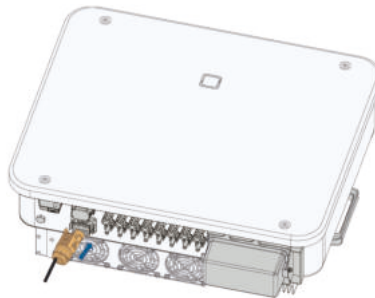

--End

5.8.4 Smart Energy Meter Connection

The inverter can provide export control but will require the use of an external smart meter. The export control functionality has not been tested to AS/NZS 4777.2:2020.

The inverter is equipped with the feed-in power limit function, so as to meet the requirements of some national standards or grid standards for the output power at the grid connection point.

Contact SUNGROW to ensure that the Smart Energy Meter model is available locally.



This section mainly describes the cable connections on the inverter side. Refer to the quick guide delivered with the Smart Energy Meter for the connections on the meter side.

Procedure

For detailed connection description of the Smart Energy Meter cable, refer to the section [5.8.3 RS485 Connection](#). Plug the wires into the **Meter** terminal according to the labels on the bottom of the inverter.

NOTICE

- The energy meter is mainly used to detect the direction and magnitude of the current. And the energy meter data may not be used for billing purposes.
- In the scenario where the meter is directly connected to the inverter, if the meter needs to be replaced midway, it is suggested to choose a new, unused meter. Otherwise, the statistics of meter energy data given by the inverter may be abnormal.

5.8.5 Dry Contact Connection

NOTICE

Dry contact cables require a cross section of 1 mm² to 1.5 mm².
The connection procedure of the dry contact is the same as that of the RS485 terminal block.

5.8.5.1 Dry Contact Function

Connection method of the dry contacts is similar to that of the RS485 terminal block.

The configuration circuit board is provided with fault output dry contact and emergency stop dry contact, as shown in the figure below.

Table 5-5 The label of COM2 terminal

DI		DRM		DO		RS485		Meter
DI	DI	C	D4/8	D2/6	COM	B1	B1	B2
PGN D	PGN D	R	D3/7	D1/5	NO	A1	A1	A2

DO terminal (fault output dry contact): The relay can be set to output fault alarms, and user can configure it to be a normally open contact (COM&NO).

Use LED indicators or other equipment to indicate whether the inverter is in the faulty state. The following Figure shows the typical application of normally open contact :

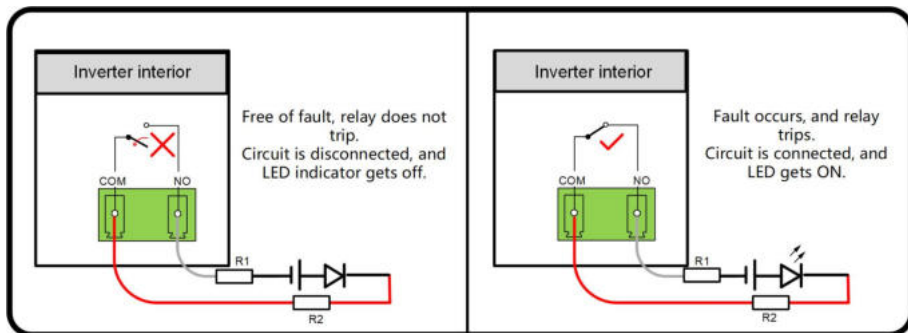

Figure 5-5 Normally open contact



- If an external load is added to the circuit, the current in the circuit cannot exceed the load's maximum current carrying capacity.
- When an external AC source is connected to the circuit, for safety concern, the lead spacing of R1 and R2 current-limiting resistors should be ≥ 8 mm respectively (you may connect multiple resistors in series to meet the spacing requirements). Also, consider whether the external loads' requirements for currents can be met after R1 and R2 resistors are connected to the circuit.

Devices connected to the relay should comply with related requirements:

AC-Side Requirements	DC-Side Requirements
Max. voltage: 250 Vac	Max. voltage: 30Vdc
Max. current: 3A	Max. current: 3A

DI terminal (emergency stop dry contact): the dry contact can be configured to be an emergency stop contact.

When the DI contact and PGND contact are shorted by external controlled switch (The external switch can be configured as normally open contact or normally closed contact), the inverter will immediately stop.

NS terminal: NS Protection is used for German market currently. For plant sized more than 30kVA, inverter NS Protection terminals could be used in daisy chain to external NS Protection Relay to realize emergency stop when NS Protection Relay change its dry contact status due to the grid abnormal running status.

NS Protection(including Passive Valid) can be set. When NS Protection is enabled on the iSolarCloud, the inverters will operate normally when DI contact and PGND contact are shorted by external controlled switch, and the inverters will emergently stop when DI contact and PGND contact are disconnected.



The dry contacts only support passive switch signal input.

The following figure shows the typical application of local stop dry contact.

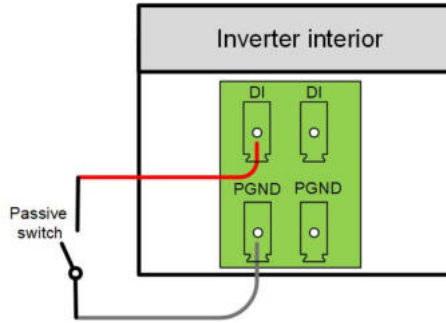

Figure 5-6 Local stop contact

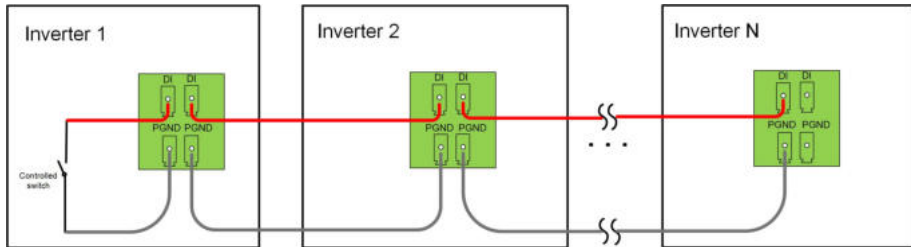

Figure 5-7 Daisy chain topology

When wiring DI dry contacts, ensure that the maximum wiring distance meet the requirements in [10.2 Wiring Distance of DI Dry Contact](#).

5.8.5.2 Wiring Procedure

For detailed connection description of the DI/DO cable, refer to the section [5.8.3 RS485 Connection](#). Plug the wires into the **DI/DO** terminal according the labels on the bottom of the inverter.

5.8.6 DRM Connection

DRM and Ripple Control support only one function at the same time.

DRM

In Australia and New Zealand, the inverter supports the demand response modes as specified in the standard AS/NZS 4777.

The following figure shows the wiring between the inverter and the external DRED.

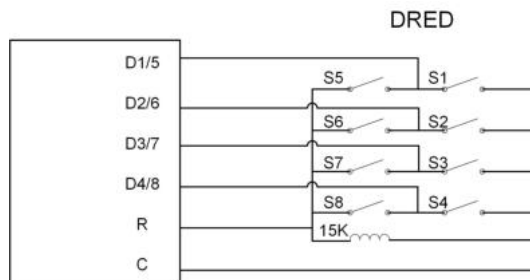

Table 5-6 Method of Asserting DRM

Mode	Asserted by Shorting Terminals on Inverter	Switch Operation on External DRED
DRM0	R & C	Close S1 and S5



Enable the DRM function through the iSolarCloud APP. If there are any problems, contact your distributor first. If the problem persists, contact SUNGROW. The DRM function is only applicable to devices for Australia and New Zealand.

Ripple Control

In Germany, the grid company uses the Ripple Control Receiver to convert the grid dispatching signal and send it as a dry contact signal.

Wiring of the ripple control receiver dry contact cables is shown in the figure below:

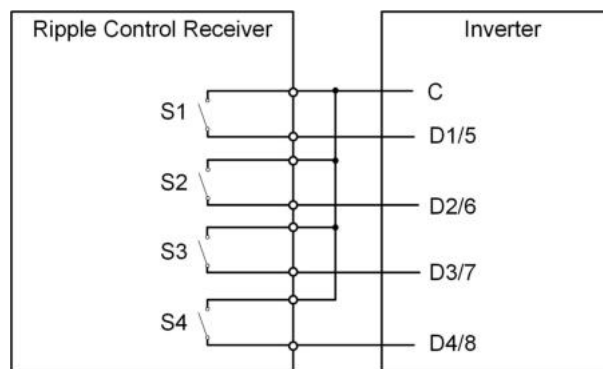
**Table 5-7** Method of Asserting DI Mode

S 1	S 2	S 3	S 4	Switch Operation on External RCR	Output power (in % of the Max. AC output power)
0	0	0	0	None	100%
1	0	0	0	Close S1	100%
0	1	0	0	Close S2	60%
0	0	1	0	Close S3	30%
1	1	0	0	Close S1 and S2	0% (disconnect from grid)

5.8.6.1 Assembling the COM Connector

Prerequisite



SUNGROW cooperates with multiple suppliers on communication connectors, so there may be cases where two types of communication connectors are received. Both communication connectors are wired in the same way, and the actual product received shall prevail.

Step 1 Unscrew the swivel nut from the connector.

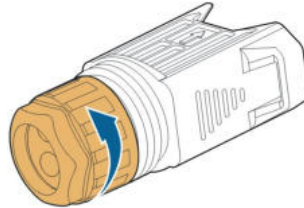

Step 2 Take out the terminal block.

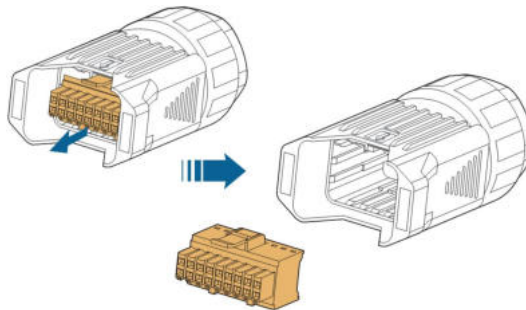

Step 3 Remove the seal and lead the cable through the cable gland.

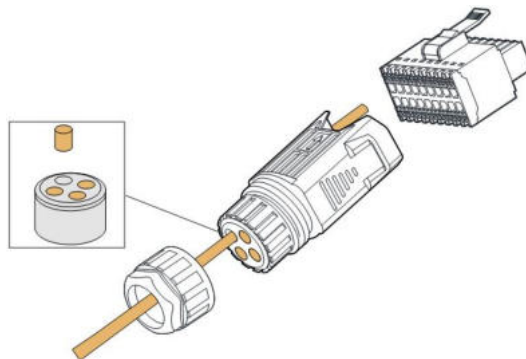

Step 4 Remove the cable jacket by 7 mm–10 mm.

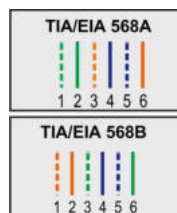

Step 5 Plug the wires into the corresponding terminal according to the labels on the bottom of the inverter.

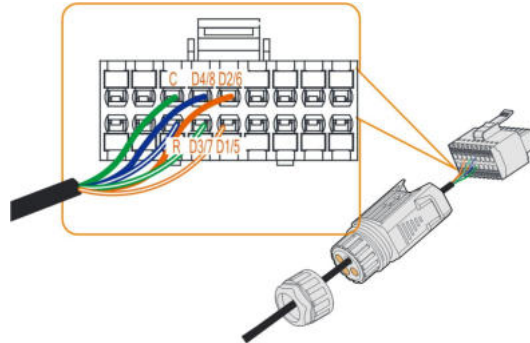

Step 6 Pull the wires outward to check whether they are firmly installed.

Step 7 Insert the terminal block into the connector until it snaps into place with an audible click.

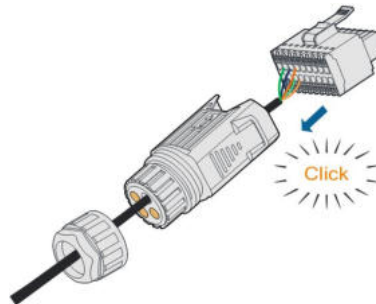

Step 8 Fasten the swivel nut.

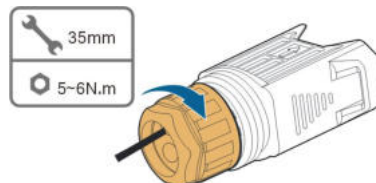

--End

5.8.6.2 Installing the COM Connector

Step 1 Remove the waterproof lid from the **COM2** terminal.

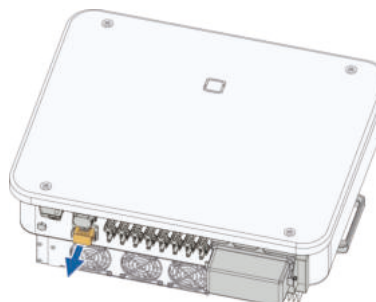

Step 2 Insert the COM connector into **COM2** terminal on the bottom of the inverter until there is an audible click.

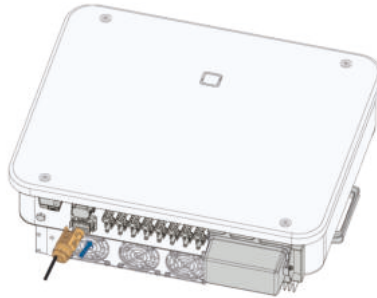

Step 3 Pull cables outwards to confirm whether they are fastened firmly.

Step 4 Connect the other end to the DRED / Ripple Control Receiver device.

--End

6 Commissioning

6.1 Inspection Before Commissioning

Check the following items before starting the inverter:

- All equipment has been reliably installed.
- DC switch(es) and AC circuit breaker are in the "OFF" position.
- The ground cable is properly and reliably connected.
- The AC cable is properly and reliably connected.
- The DC cable is properly and reliably connected.
- The communication cable is properly and reliably connected.
- The unused terminals are sealed.
- No foreign items, such as tools, are left on the top of the machine or in the junction box (if there is).
- The AC circuit breaker is selected in accordance with the requirements of this manual and local standards.
- All warning signs & labels are intact and legible.



If the inverter has been mounted but remains non-operational for more than three months, it must be inspected and tested by qualified personnel before being put into operation.

6.2 Commissioning Procedure

Prerequisite

If all of the items mentioned above meet the requirements, proceed as follows to start up the inverter for the first time.

Step 1 Rotate the DC switch of the inverter to the "ON" position, the indicator blinks blue slowly.

NOTICE

- **Strictly follow the preceding sequence. Otherwise, the product may be damaged, and the loss caused is not covered by the warranty.**
- **If the DC side is powered up while the AC side is not, the inverter indicator may turn red, and the inverter will report a fault named “Grid Power Outage” (the fault information can be viewed on the iSolarCloud App, see “Records” for details). The fault is automatically cleared when the AC circuit breaker between the inverter and the grid is closed.**
- **Before closing the AC circuit breaker between the inverter and the power grid, use a multimeter that is set to the AC gear to ensure that the AC voltage is within the specified range. Otherwise, the inverter may be damaged.**

Step 2 Close the AC circuit breaker between the inverter and the grid.

Step 3 Install the iSolarCloud App, see [7.2 Install iSolarCloud](#) for details.

Step 4 Set initial protection parameters via the iSolarCloud App when the inverter is connected to the grid for the first time. If the irradiation and grid conditions meet requirements, the inverter normally operates.

Step 5 The home page is automatically displayed when the setting is completed. The indicator is steady blue, and the inverter is in grid-connected operation.

--End

6.3 Optimizer Physical Layout (Optional)

- If PV modules are installed and optimizers are configured, check to ensure that all devices are reliably installed.
- Remove QR code labels from the optimizers and attach them to corresponding square cells on the physical layout.
- Please refer to the optimizer user manual for details of the optimizer physical layout.
- For details about plant creation and optimizer layout setup on the iSolarCloud App.



NOTICE

- **In the multi-inverter scenario where optimizers are installed, start the inverters one by one in the proper order. Do not start the inverters all at the same time.**
- **In case the PV system, where the inverter is installed, is equipped with optimizers and the physical layout of optimizers has been successfully set, before removing the optimizers from the system or relocating the inverter to a PV system with no optimizers, please clear the physical layout of optimizers via iSolarCloud.**

7 iSolarCloud App

7.1 About iSolarCloud

The iSolarCloud App is a mobile application used for power plant management. The App provides plant operation analysis service and enables intelligent mobile O&M. It is designed with functions such as plant operation data display, rapid plant access, parameter setting, quick fault location and notification, and power yield and revenue analysis. With iSolarCloud, convenient and efficient end-to-end plant O&M is allowed.

Connection Methods

Users can log in to the App via remote connection or local access for plant monitoring.

Login by Establishing a Direct Connection (Local)

Establish communication between the mobile phone and the WiFi wireless communication module or the inverter's built-in Bluetooth module to enable mobile maintenance of the inverter. After logging into the App, users can check the information about and set parameters for the inverter.



Direct Login (Local)



Login via Bluetooth connection is applicable only for SUNGROW inverters with built-in Bluetooth modules. Please consult your retailer/installer about whether the inverter is equipped with a Bluetooth module.

Login with an Account (Remote)

Establish communication between the communication module and the home router or base station to enable data exchange between the inverter and the cloud server. After logging

into the App, users can check the inverter data or send commands to control the inverter on the App.

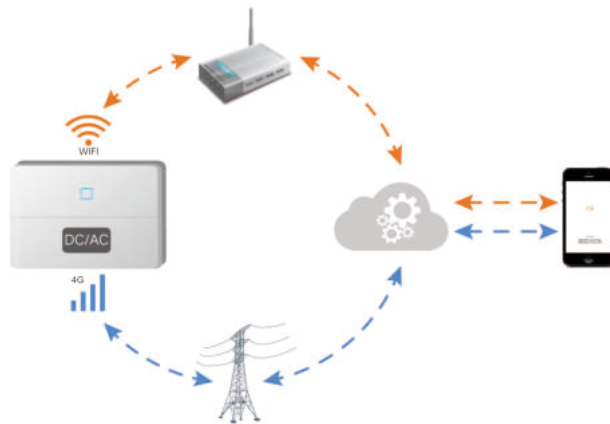

Login Via Account and Password (Remote)

7.2 Install iSolarCloud

Prerequisite

This section introduces how to download and install the iSolarCloud App.

Procedure

- Step 1** Search for **iSolarCloud** in App Store, Google Play or other App stores, or scan the QR code below with a mobile phone and download the App by following the onscreen instructions.



- Step 2** Tap the downloaded installation package and follow the onscreen instructions to complete the installation. The icon of iSolarCloud will then appear on the screen.

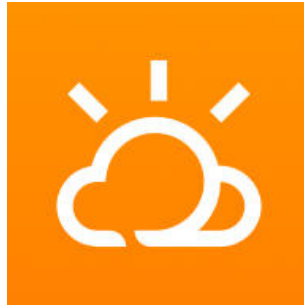

--End

7.3 User Roles

After logging into the iSolarCloud App with different roles, users will have varying levels of access to device operations. The default accounts and passwords corresponding to different user roles can be found in [iSolarCloud App User Manual Device Commissioning \(V2.1.6.20250218or Later\)](#) > **Device Connection** > **Device Connection via WLAN** > **Identity Verification**.

For account security purposes, please refer to the **Identity Verification** section to change your password promptly after logging into the iSolarCloud App.

7.4 Device Commissioning

For device commissioning operations, please refer to the **Device Commissioning** in the [iSolarCloud App User Manual](#). Alternatively, you can scan the QR code below to access the **Device Commissioning** section of the manual.



8 System Decommissioning

8.1 Disconnecting the Inverter

Prerequisite

CAUTION

Danger of burns!
Even if the inverter is shut down, it may still be hot and cause burns. Wear protective gloves before operating the inverter after it cools down.

For maintenance or other service work, the inverter must be switched off. Proceed as follows to disconnect the inverter. Lethal voltages or damage to the inverter will follow if otherwise.

Step 1 Disconnect the external AC circuit breaker and prevent it from inadvertent reconnection.

Step 2 Rotate the DC switch to the "OFF" position for disconnecting all of the PV string inputs.

Step 3 Wait about 15 minutes until the capacitors inside the inverter completely discharge.

Step 4 Ensure that the DC cable is current-free with a current clamp.

--End

8.2 Dismantling the Inverter

Prerequisite

CAUTION

Risk of burn injuries and electric shock!
After the inverter is powered off for 15 minutes, measure the voltage and current with professional instrument. Only when there is no voltage nor current can operators who wear protective equipment operate and maintain the inverter.



- Before dismantling the inverter, disconnect the inverter from both AC and DC power sources.
- If there are more than two layers of inverter DC terminals, dismantle the outer DC connectors before dismantling the inner ones.
- If the original packing materials are available, put the inverter inside them and then seal them using adhesive tape. If the original packing materials are not available, put the inverter inside a cardboard box suitable for the weight and size of this inverter and seal it properly.

- Step 1** Refer to [5 Electrical Connection](#) to disconnect all cables in reverse steps. In particular, when removing the DC connector, use a connector wrench to loosen the locking parts and install waterproof plugs.

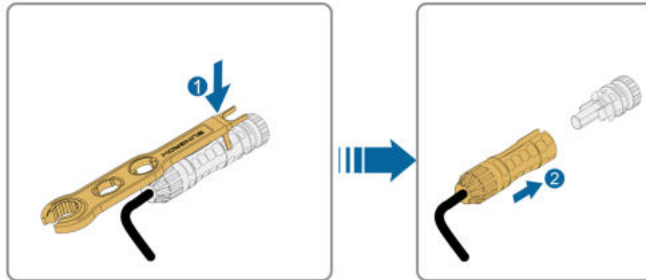

- Step 2** Refer to [4 Mechanical Mounting](#), to dismantle the inverter in reverse steps.
- Step 3** If necessary, remove the wall-mounting bracket from the wall.
- Step 4** If the inverter will be used again in the future, please refer to [3.2 Inverter Storage](#) for a proper conservation.
- End

8.3 Replacing the Inverter

8.3.1 Replacement via Communication Module/Logger

Prerequisite

Users can replace the inverter using a communication module/data logger and set the address of the new inverter to that of the old one.

- Step 1** Remove the old inverter, by referring to [8.2 Dismantling the Inverter](#), and install the new inverter. After that, connect the new inverter to the WiNet-S/WiNet-S2/Logger, log in to the Web system of the corresponding device, and choose **Device Maintenance > Device List**.

Then, click  in the "Action" column and, in the **Edit Device** window, change the device address of the new inverter to that of the old one. For example, if the device address of the old inverter is "1", set the device address of the new inverter to "1".

- Step 2** After the WiNet-S/WiNet-S2/Logger is restarted, the system will automatically search for the new device, and the address for forwarding of the new device will be the same as the old one.
- Step 3** The device on the cloud will be replaced automatically after the communication module/logger accesses the cloud.
- End

8.3.2 Replacement via iSolarCloud

Prerequisite

The device address of the new inverter is different from the address of the old one.

- Step 1** Remove the old inverter by referring to [8.2 Dismantling the Inverter](#). Then, install the new inverter.
- Step 2** Connect the new inverter to the WiNet-S/WiNet-S2/Logger. Then, restart the WiNet-S/WiNet-S2/Logger, log in to the iSolarCloud App, and find the plant created based on the WiNet-S/WiNet-S2/Logger. Ensure the WiNet-S/WiNet-S2/Logger is connected to the iSolarCloud.
- Step 3** Find the inverter that needs to be replaced. Click *** in the upper right corner, choose **Device Replacement**, and click **Add New Device**. Check that the new inverter is online, and click **Confirm** to replace the device.

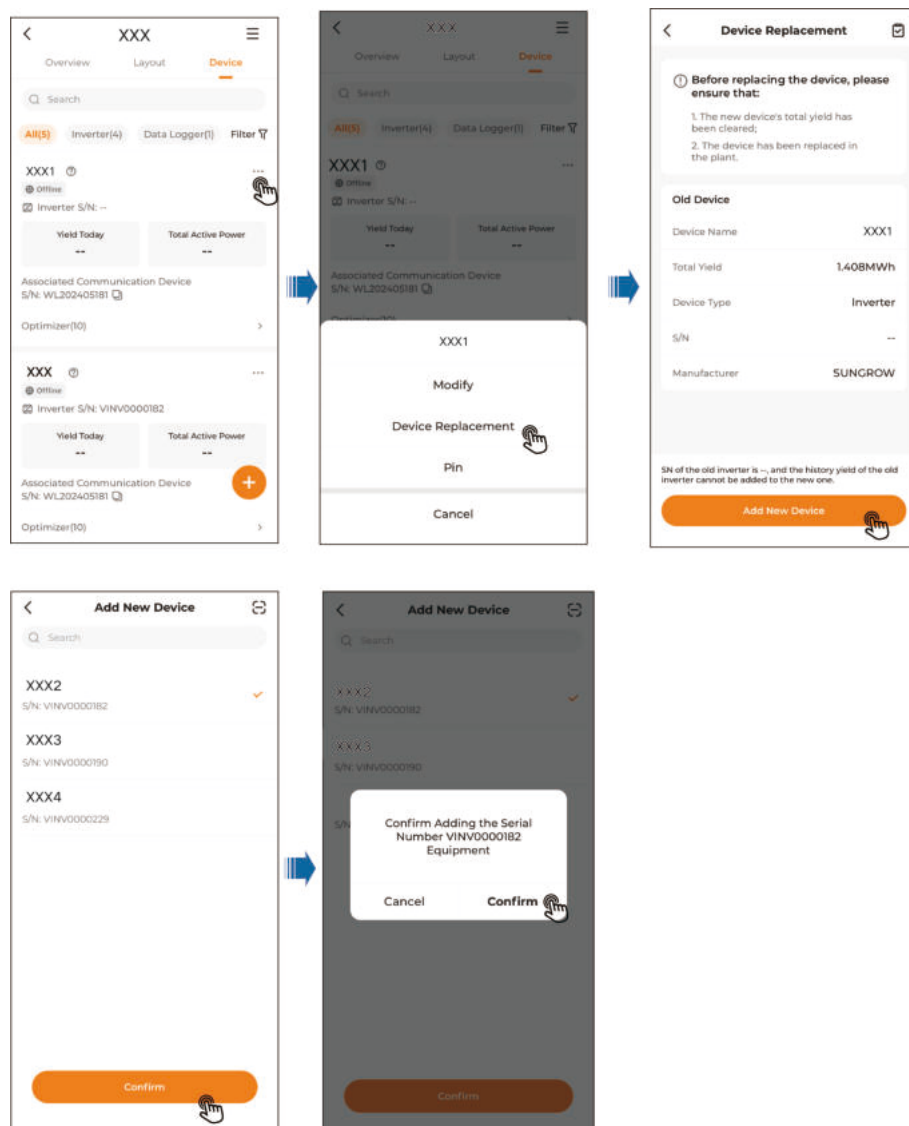

- Step 4** Go to the **Device** screen and wait about 5–10 minutes, until the S/N of the new inverter is shown on the screen instead. The inverter replacement is now completed.

--End

8.4 Disposal of Inverter

Users take the responsibility for the disposal of the inverter.

WARNING

Please scrap the inverter in accordance with relevant local regulations and standards to avoid property losses or casualties.

NOTICE

Some parts of the inverter may cause environmental pollution. Please dispose of them in accordance with the disposal regulations for electronic waste applicable at the installation site.

9 Troubleshooting and Maintenance

9.1 Troubleshooting

Once the inverter fails, the fault information is displayed on the App interface. If the inverter is equipped with an LCD screen, the fault information can be viewed on it.

The fault codes and troubleshooting methods of all PV inverters are detailed in the table below, and only some of the faults may occur to the model you purchased. When a fault occurs, you can check the fault information according to the fault code on the mobile app.

Fault Code	Fault Name	Troubleshooting Method
2, 3, 14, 15	Grid Overvoltage	<p>Generally, the inverter will be reconnected to the grid after the grid returns to normal. If the fault occurs repeatedly:</p> <ol style="list-style-type: none">1. Measure the actual grid voltage, and contact the local electric power company for solutions if the grid voltage is higher than the set value.2. Check whether the protection parameters are appropriately set via the App or the LCD. Modify the overvoltage protection values with the consent of the local electric power operator.3. Contact Sungrow Customer Service if the preceding causes are ruled out and the fault persists.
4, 5	Grid Undervoltage	<p>Generally, the inverter will be reconnected to the grid after the grid returns to normal. If the fault occurs repeatedly:</p> <ol style="list-style-type: none">1. Measure the actual grid voltage, and contact the local electric power company for solutions if the grid voltage is lower than the set value.2. Check whether the protection parameters are appropriately set via the App or the LCD.3. Check whether the AC cable is firmly in place.4. Contact Sungrow Customer Service if the preceding causes are ruled out and the fault persists.

Fault Code	Fault Name	Troubleshooting Method
8	Grid Overfrequency	<p>Generally, the inverter will be reconnected to the grid after the grid returns to normal. If the fault occurs repeatedly:</p> <ol style="list-style-type: none"> 1. Measure the actual grid frequency, and contact the local electric power company for solutions if the grid frequency is beyond the set range.
9	Grid Underfrequency	<ol style="list-style-type: none"> 2. Check whether the protection parameters are appropriately set via the App or the LCD. 3. Contact Sungrow Customer Service if the preceding causes are ruled out and the fault persists.
10	Grid Power Outage	<p>Generally, the inverter will be reconnected to the grid after the grid returns to normal. If the fault occurs repeatedly:</p> <ol style="list-style-type: none"> 1. Check whether the grid supplies power reliably. 2. Check whether the AC cable is firmly in place. 3. Check whether the AC cable is connected to the correct terminal (whether the live wire and the N wire are correctly in place). 4. Check whether the AC circuit breaker is connected. 5. Contact Sungrow Customer Service if the preceding causes are ruled out and the fault persists.
12	Excess Leakage Current	<ol style="list-style-type: none"> 1. The fault can be caused by poor sunlight or damp environment, and generally the inverter will be reconnected to the grid after the environment is improved. 2. If the environment is normal, check whether the AC and DC cables are well insulated. 3. Contact Sungrow Customer Service if the preceding causes are ruled out and the fault persists.
13	Grid Abnormal	<p>Generally, the inverter will be reconnected to the grid after the grid returns to normal. If the fault occurs repeatedly:</p>

Fault Code	Fault Name	Troubleshooting Method
		<ol style="list-style-type: none"> 1. Measure the actual grid, and contact the local electric power company for solutions if the grid parameter exceeds the set range. 2. Contact Sungrow Customer Service if the preceding causes are ruled out and the fault persists.
17	Grid Voltage Imbalance	<p>Generally, the inverter will be reconnected to the grid after the grid returns to normal. If the fault occurs repeatedly:</p> <ol style="list-style-type: none"> 1. Measure the actual grid voltage. If grid phase voltages differ greatly, contact the electric power company for solutions. 2. If the voltage difference between phases is within the permissible range of the local power company, modify the grid voltage imbalance parameter through the App or the LCD. 3. Contact Sungrow Customer Service if the preceding causes are ruled out and the fault persists.
28, 29, 208, 212, 448-479	PV Reserve Connection Fault	<ol style="list-style-type: none"> 1. Check whether the corresponding string is of reverse polarity. If so, disconnect the DC switch and adjust the polarity when the string current drops below 0.5 A. 2. Contact Sungrow Customer Service if the preceding causes are ruled out and the fault persists. <p>*The code 28 to code 29 are corresponding to PV1 to PV2 respectively. *The code 448 to code 479 are corresponding to string 1 to string 32 respectively.</p>
532-547, 564-579	PV Reverse Connection Alarm	<ol style="list-style-type: none"> 1. Check whether the corresponding string is of reverse polarity. If so, disconnect the DC switch and adjust the polarity when the string current drops below 0.5 A. 2. Contact Sungrow Customer Service if the preceding causes are ruled out and the alarm persists. <p>*The code 532 to code 547 are corresponding to string 1 to string 16 respectively. *The code 564 to code 579 are corresponding to string 17 to string 32 respectively.</p>

Fault Code	Fault Name	Troubleshooting Method
548-563, 580-595	PV Abnormal Alarm	<p>Check whether the voltage and current of the inverter is abnormal to determine the cause of the alarm.</p> <ol style="list-style-type: none"> 1. Check whether the corresponding module is sheltered. If so, remove the shelter and ensure module cleanness. 2. Check whether the battery board wiring is loose, if so, make it reliably connected. 3. Check if the DC fuse is damaged. If so, replace the fuse. 4. Contact Sungrow Customer Service if the preceding causes are ruled out and the alarm persists. <p>*The code 548 to code 563 are corresponding to string 1 to string 16 respectively. *The code 580 to code 595 are corresponding to string 17 to string 32 respectively.</p>
37	Excessively High Ambient Temperature	<p>Generally, the inverter will resume operation when the internal or module temperature returns to normal. If the fault persists:</p> <ol style="list-style-type: none"> 1. Check whether the ambient temperature of the inverter is too high; 2. Check whether the inverter is in a well-ventilated place; 3. Check whether the inverter is exposed to direct sunlight. Shield it if so; 4. Check whether the fan is running properly. Replace the fan if not; 5. Contact Sungrow Power Customer Service if the fault is due to other causes and the fault persists.
43	Excessively Low Ambient Temperature	<p>Stop and disconnect the inverter. Restart the inverter when the ambient temperature rises within the operation temperature range.</p>
39	Low System Insulation Resistance(Earth Fault)	<p>Wait for the inverter to return to normal. If the fault occurs repeatedly:</p> <ol style="list-style-type: none"> 1. Check whether the ISO resistance protection value is excessively high via the app or the LCD, and ensure that it complies with the local regulations.

Fault Code	Fault Name	Troubleshooting Method
		<ol style="list-style-type: none"> 2. Check the resistance to ground of the string and DC cable. Take corrective measures in case of short circuit or damaged insulation layer. 3. If the cable is normal and the fault occurs on rainy days, check it again when the weather turns fine. 4. If there are batteries, check whether battery cables are damaged and whether terminals are loose or in poor contact. If so, replace the damaged cable and secure terminals to ensure a reliable connection. 5. Contact Sungrow Customer Service if the preceding causes are ruled out and the fault persists.
106	Grounding Cable Fault	<ol style="list-style-type: none"> 1. Check whether the AC cable is correctly connected. 2. Check whether the insulation between the ground cable and the live wire is normal. 3. Contact Sungrow Customer Service if the preceding causes are ruled out and the fault persists.
88	Electric Arc Fault	<ol style="list-style-type: none"> 1. Disconnect the DC power supply, and check whether any DC cable is damaged, the connection terminal or fuse is loose or there is a weak contact. If so, replace the damaged cable, fasten the terminal or fuse, and replace the burnt component. 2. After performing step 1, reconnect the DC power supply, and clear the electric arc fault via the App or the LCD, after that the inverter will return to normal. 3. Contact Sungrow Customer Service if the fault persists.
84	Reverse Connection Alarm of the Meter/CT	<ol style="list-style-type: none"> 1. Check if the meter is wrongly connected. 2. Check if the input and output wiring of the meter is reversed. 3. If the existing system is enabled, please check if the rated power setting of the existing inverter is correct.

Fault Code	Fault Name	Troubleshooting Method
514	Meter Communication Abnormal Alarm	<ol style="list-style-type: none"> 1. Check whether the communication cable and the terminals are abnormal. If so, correct them to ensure reliable connection. 2. Reconnect the communication cable of the meter. 3. Contact Sungrow Customer Service if the preceding causes are ruled out and the alarm persists.
323	Grid Confrontation	<ol style="list-style-type: none"> 1. Check whether the output port is connected to actual grid. Disconnect it from the grid if so. 2. Contact Sungrow Customer Service if the preceding causes are ruled out and the fault persists.
75	Inverter Parallel Communication Alarm	<ol style="list-style-type: none"> 1. Check whether the communication cable and the terminals are abnormal. If so, correct them to ensure reliable connection. 2. Reconnect the communication cable of the meter. 3. Contact Sungrow Customer Service if the preceding causes are ruled out and the alarm persists.
71	AC-side SPD Failure	Check the AC SPD and replace the control board assembly.
72	DC-side SPD Failure	<ol style="list-style-type: none"> 1. Check whether the connection between the control board and the main power board is reliable. 2. Check the DC SPD and replace the main power board assembly. 3. If the fault is not cleared after the main power board is replaced, replace the control board.
7, 11, 16, 19–25, 30–34, 36, 38, 40–42, 44–50, 52–58, 60–69, 85, 87, 92, 93, 100–105, 107–114, 116–124,	System Fault	<p>Wait for the inverter to return to normal. If the fault occurs repeatedly:</p> <ol style="list-style-type: none"> 1. Wait for the inverter to return to normal. 2. Disconnect the AC and DC switches, and disconnect the battery side switches if there are batteries. Close the AC and DC switches in turn 15 minutes later and restart the system.

Fault Code	Fault Name	Troubleshooting Method
200–211, 248–255, 300–322, 324–328, 401–412, 600–603, 605, 608, 612, 616, 620, 622– 624, 800, 802, 804, 807, 1096– 1118, 681		3. Contact Sungrow Customer Service if the preceding causes are ruled out and the fault persists.
59, 70–74, 76–83, 89, 216–218, 220–233, 432–434, 500–513, 515–518, 635–638, 900, 901, 910, 911, 996	System Alarm	<ol style="list-style-type: none"> The inverter can continue running. Check whether the related wiring and terminal are abnormal, check whether there are any foreign materials or other environmental abnormalities, and take corresponding corrective measures when necessary. If the fault persists, please contact Sungrow Power Customer Service.
264-283	MPPT Reverse Connection	<ol style="list-style-type: none"> Check whether the corresponding string is of reverse polarity. If so, disconnect the DC switch and adjust the polarity when the string current drops below 0.5 A. Contact Sungrow Customer Service if the preceding causes are ruled out and the fault persists. <p>*The code 264 to code 279 are corresponding to string 1 to string 20 respectively.</p>
332-363	Boost Capacitor Overvoltage Alarm	<ol style="list-style-type: none"> The inverter can continue running. Check whether the related wiring and terminals are abnormal, check whether there are any foreign materials or other environmental abnormalities, and take corresponding corrective measures when necessary. <p>If the fault persists, please contact Sungrow Power Customer Service.</p>

Fault Code	Fault Name	Troubleshooting Method
364-395	Boost Capacitor Overvoltage Fault	<ol style="list-style-type: none"> 1. Disconnect the AC and DC switches, and disconnect the battery side switches if there are batteries. Close the AC and DC switches in turn 15 minutes later and restart the system. 2. If the fault persists, please contact Sungrow Power Customer Service.
1548-1579	String Current Reflux	<ol style="list-style-type: none"> 1. Check whether the number of PV modules of the corresponding string is less than other strings. If so, disconnect the DC switch and adjust the PV module configuration when the string current drops below 0.5 A. 2. Check whether the PV module is shaded; 3. Disconnect the DC switch to check whether the open circuit voltage is normal when the string current drops below 0.5 A. If so, check the wiring and configuration of the PV module, 4. Check whether the orientation of the PV module is abnormal.
1600 - 1615, 1632 - 1655	PV Grounding Fault	<ol style="list-style-type: none"> 1. When the fault occurs, it is forbidden to directly disconnect the DC switch and unplug PV terminals when the direct current is greater than 0.5 A; 2. Wait until the direct current of the inverter falls below 0.5 A, then disconnect the DC switch and unplug the faulty strings; 3. Do not reinsert the faulty strings before the grounding fault is cleared; 4. If the fault is not caused by the foregoing reasons and still exists, contact Sungrow Customer Service.
1328	PV cable-to-ground short circuit	<ol style="list-style-type: none"> 1. Check the impedance-to-ground of PV arrays and PV cables. If poor insulation or a short circuit is found, rectify the fault. 2. If the fault persists or cannot be automatically cleared, contact Sungrow Customer Service.
1616	System Hardware Fault	<ol style="list-style-type: none"> 1. It is prohibited to disconnect the DC switch when the DC current is greater than 0.5 A when the fault occurs.

Fault Code	Fault Name	Troubleshooting Method
		2. Disconnect the DC switch only when the inverter DC side current drops below 0.5 A. 3. It is prohibited to power up the inverter again. Please contact Sungrow Customer Service.

Once a fault occurs to the optimizer or RSD, the fault information is displayed on the App.

Fault Code	Fault Name	Possible Cause	Troubleshooting Method
4	Input overvoltage	The PV voltage is higher than the set protection value	Check whether the open-circuit voltage of the PV module connected to the optimizer exceeds the maximum input voltage allowed by the optimizer.
512	Hardware fault	A hardware fault occurs to the optimizer	Please contact Sungrow Customer Service.
1024	Update failed	The optimizer software fails to upgrade	1. Check the light condition, and update the optimizer again if the light is normal. 2. If the fault persists, please contact Sungrow Customer Service.



- If there is a string current backfeed fault, first check whether the optimizer is offline.
- Contact the dealer if the measures listed in the “Troubleshooting Method” column have been taken but the problem persists. Contact SUNGROW if the dealer fails to solve the problem.

9.2 Maintenance

9.2.1 Maintenance Notices

DANGER

Risk of inverter damage or personal injury due to incorrect service!

- Be sure to use special insulation tools when perform high-voltage operations.
- Before maintenance, disconnect the AC circuit breaker on the grid side and then the DC switch. If a fault that may cause personal injury or device damage is found before maintenance, disconnect the AC circuit breaker and wait until the night before operating the DC switch. Otherwise, a fire inside the product or an explosion may occur, causing personal injuries.
- After the inverter is powered off for 15 minutes, measure the voltage and current with professional instrument. Only when there is no voltage nor current can operators who wear protective equipment operate and maintain the inverter
- Even if the inverter is shut down, it may still be hot and cause burns. Wear protective gloves before operating the inverter after it cools down.

DANGER

When maintaining the product, it is strictly prohibited to open the product if there is an odor or smoke or if the product appearance is abnormal. If there is no odor, smoke, or obvious abnormal appearance, repair or restart the inverter according to the alarm corrective measures. Avoid standing directly in front of the inverter during maintenance.

CAUTION

To prevent misuse or accidents caused by unrelated personnel: Post prominent warning signs or demarcate safety warning areas around the inverter to prevent accidents caused by misuse.

NOTICE

Restart the inverter only after removing the fault that impairs safety performance. As the inverter contains no component parts that can be maintained, never open the enclosure, or replace any internal components. To avoid the risk of electric shock, do not perform any other maintenance operations beyond this manual. If necessary, contact your distributor first. If the problem persists, contact SUNGROW. Otherwise, the losses caused is not covered by the warranty.

NOTICE

Touching the PCB or other static sensitive components may cause damage to the device.

- Do not touch the circuit board unnecessarily.
- Observe the regulations to protect against electrostatic and wear an anti-static wrist strap.

9.2.2 Rapid Shutdown

The PV system can perform a rapid shutdown, reducing the output voltage of strings to below 30 V within 30 s.

Triggering methods of rapid shutdown:

- Method 1: Turn off the AC circuit breaker between the inverter and the grid.
- Method 2: Connect DI and PGND in COM2 port to trigger rapid shutdown. Disconnect DI and PGND to exit the rapid shutdown mode.
- Method 3: Connect the rapid shutdown button to any DI port (except DI5) on the Logger1000. Then, log in to the Logger1000 web system and configure the DI port parameters. After this, rapid shutdown can be triggered by pressing the rapid shutdown button.
- Method 4: Enable "AFCI-Triggered Rapid Shutdown" manually. Then, in case of an arc fault in the inverter, a "rapid shutdown" signal will be sent to the optimizer and the inverter will execute the "press to shut down" and "rapid shutdown" commands simultaneously.

NOTICE

- The rapid shutdown is not supported if optimizers are configured for partial MPPT deployment scenario.
- Please check regularly whether the rapid shutdown function is normal.
- Rapid shutdown cannot be achieved by turning off the inverter's DC switch.

9.2.3 Routine Maintenance

Item	Method	Period
Device clean	Check whether the air outlet and heat sink are blocked by dust and other objects. Check if the air inlet and outlet are normal. Clean the air inlet and outlet, if necessary.	Six months to a year (depend on the dust contents in air)
Fans	Check whether there is a fan alarm on the App.	Once a year

Item	Method	Period
	<p>Check whether there is any abnormal noise when the fan is rotating.</p> <p>Clean or replace the fans if necessary (see the following section).</p>	
Cable entry	Check whether the cable entry is insufficiently sealed or the gap is excessively large, and reseal the entry when necessary.	Once a year
Electrical connection	<p>Check whether cables are loose or fall off.</p> <p>Check whether the cable is damaged, especially the part in contact with the metal enclosure.</p>	Six months to a year

9.2.4 Cleaning Air Inlet and Outlet

A significant amount of heat is generated when the inverter is working.

In order to maintain good ventilation, please check to make sure the air inlet and outlet are not blocked.

Clean the air inlet and outlet with soft brush or vacuum cleaner if necessary.

9.2.5 Fan Maintenance

DANGER

- **Power off the inverter and disconnect it from all power supplies before maintaining fans.**
- **After the inverter is powered off for 15 minutes, measure the voltage and current with professional instrument. Only when there is no voltage nor current can operators who wear protective equipment operate and maintain the inverter.**
- **Fan maintenance must be performed by professionals.**

Fans inside the inverter are used to cool the inverter during operation. If the fans do not operate normally, the inverter may not be cooled down and inverter efficiency may decrease. Therefore, it is necessary to clean dirty fans and replace the broken fans in a timely manner.

The operation procedure is as follows:

Step 1 Stop the inverter(see 8.1 [Disconnecting the Inverter](#))

Step 2 Loosen the screw on the sealing plate of the fan module.

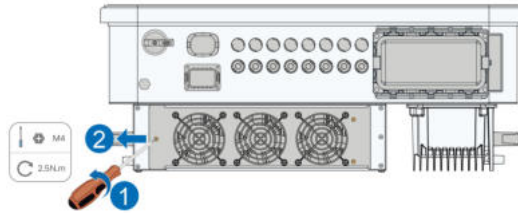

Step 3 Press the tab of the latch hook, unplug the cable connection joint outwards, and loosen the screw on the fan holder.

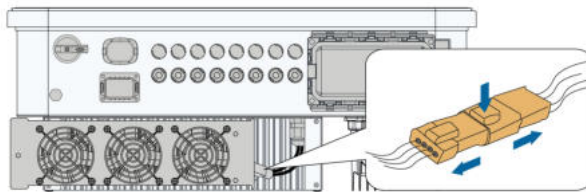

Step 4 Pull out the fan module, clean the fans with soft brush or vacuum cleaner, and replace them when necessary.

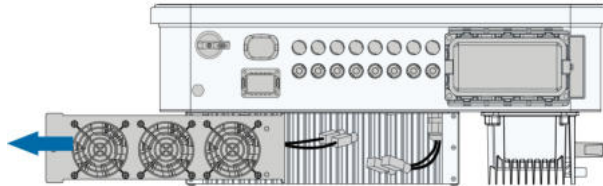

Step 5 Reinstall the fan back to the inverter in reverse order and restart the inverter.

--End

10 Appendix

10.1 Technical Data

Parameters	SG25C X-P2	SG30 CX-P2	SG33C X-P2	SG36C X-P2	SG40CX -P2	SG50C X-P2	
Input (DC)							
Recommended max. PV input power	35 kWp	42 kWp	46.2 kWp	50.4 kWp	56 kWp	70 kWp	
Max. PV input voltage	1100 V						
Min. PV input voltage / Startup input voltage	160 V / 200 V						
Rated PV input voltage	600 V						
MPP voltage range	160 V ~ 1000 V						
MPP voltage range for rated power	400 V ~ 800 V ⁽¹⁾	500 V ~ 800 V ⁽¹⁾					
No. of independent MPP inputs		3			4		
No. of PV strings per MPPT		2			2		
Max. PV input current	90 A (30 A * 3)		120 A (30 A * 4)				
Max. DC short-circuit current	120 A (40 A * 3)		160 A (40 A * 4)				

Parameters	SG25C X-P2	SG30 CX-P2	SG33C X-P2	SG36C X-P2	SG40CX -P2	SG50C X-P2
Max. current for DC connector	30A					
Output (AC)						
Rated AC output power	25 kW	30 kW	33 kW	36 kW	40 kW	50 kW
Max. AC output power	27.5 kVA	33 kVA ⁽²⁾	36.3 kVA	40 kVA	44 kVA	55 kVA
Max. AC output current	41.8 A	50.2 A	55.2 A	60.2 A	66.9 A	83.6 A
Rated AC output current (at 230V)	36.2 A	43.5 A	47.8 A	52.17 A	58 A	72.5 A
Rated AC voltage	3 / N / PE, 220 / 380 V, 230 / 400 V					
AC voltage range	312 ~ 480 V					
Rated grid frequency	50 Hz / 60 Hz					
Grid frequency range	45 – 55 Hz / 55 – 65 Hz					
Harmonic (THD)	< 3 % (at Rated power)					
Power factor at Rated power / Adjustable power factor	> 0.99 / 0.8 leading – 0.8 lagging					
Feed-in phases / connection phases	3 / 3-N-PE					

Parameters	SG25C X-P2	SG30 CX-P2	SG33C X-P2	SG36C X-P2	SG40CX -P2	SG50C X-P2
Efficiency						
Max. efficiency / European efficiency	98.4% / 98.2%			98.5% / 98.3%		
Protection						
Grid monitoring				Yes		
DC reverse connection protection				Yes		
AC short-circuit protection				Yes		
Leakage current protection				Yes		
Surge protection			DC Type I+II / AC Type II			
Ground fault monitoring				Yes		
DC switch				Yes		
PV String current monitoring				Yes		
Arc fault circuit interrupter (AFCI)				Yes		
PID recovery function				Yes		
Optimizer compatibility ⁽³⁾				Optional		

Parameters	SG25C X-P2	SG30 CX-P2	SG33C X-P2	SG36C X-P2	SG40CX -P2	SG50C X-P2
RSD compatibility ⁽³⁾	Optional					
General Data						
Dimensions (W*H*D)	645*575*245 mm					
Mounting Method	Wall-mounting bracket					
Weight	38 kg			40 kg	40 kg	41 kg
Topology	Transformerless					
Degree of protection	IP66					
Corrosion	C5					
Night power consumption	< 7 W					
Operating ambient temperature range	-30 to 60 °C					
Allowable relative humidity range (non- condensing)	0 – 100 %					
Cooling method	Smart forced air cooling					
Max. operating altitude	4000 m					
Display	LED, Bluetooth+APP					
Communication	RS485 / Optional: WLAN, Ethernet					

Parameters	SG25C X-P2	SG30 CX-P2	SG33C X-P2	SG36C X-P2	SG40CX -P2	SG50C X-P2
DC connection type			EVO2 (Max. 6 mm ²)			
AC connection type		OT terminal (16~35 mm ²)				OT or DT terminal (35~50 mm ²)
AC Cable specification		Outside diameter 18~38mm				
Grid Support	Q at night function, LVRT, HVRT, active & reactive power control and power ramp rate control					

Note(1):

- The voltage difference between MPPTs should be less than 80 V.
- The voltage of the configured string should be higher than the lower limit of the rated MPPT voltage.

Note(2): 30kVA for Germany, Belgium, Austria, Ukraine and Denmark, 33kVA for others.

Note(3): For SP600S optimizer & SR20D-M RSD compatibility, please consult Sungrow before placing an order.

Parameter	SG25C X-P2 ⁽⁴⁾	SG30CX -P2 ⁽⁴⁾	SG33C X-P2 ⁽⁴⁾	SG36CX -P2 ⁽⁴⁾	SG40CX -P2 ⁽⁴⁾	SG50CX -P2 ⁽⁴⁾
Input (DC)						
Recommended max. PV input power	35 kWp	42 kWp	46.2 kWp	50.4 kWp	56 kWp	70 kWp
Max. PV input voltage	1100 V					
Min. PV input voltage / Startup	160 V / 200 V					

Parameter s	SG25C X-P2 ⁽⁴⁾	SG30CX -P2 ⁽⁴⁾	SG33C X-P2 ⁽⁴⁾	SG36CX -P2 ⁽⁴⁾	SG40CX -P2 ⁽⁴⁾	SG50CX -P2 ⁽⁴⁾
input voltage						
Rated PV input voltage				600 V		
MPP voltage range				160 V ~ 1000 V		
MPP voltage range for rated power	400 V ~ 800 V ⁽⁵⁾			500 V ~ 800 V ⁽⁵⁾		
No. of independe nt MPP inputs		3			4	
No. of PV strings per MPPT		2			2	
Max. PV input current		90 A (30 A * 3)			120 A (30 A * 4)	
Max. DC short- circuit current		120 A (40 A * 3)			160 A (40 A * 4)	
Max. current for DC connector				30 A		
Output (AC)						
Rated AC output power	25 kW	30 kW	33 kW	36 kW	40 kW	50 kW

Parameter s	SG25C X-P2 ⁽⁴⁾	SG30CX -P2 ⁽⁴⁾	SG33C X-P2 ⁽⁴⁾	SG36CX -P2 ⁽⁴⁾	SG40CX -P2 ⁽⁴⁾	SG50CX -P2 ⁽⁴⁾
Max. AC output power	27.5 kVA	33 kVA (6)	36.3 kVA	40 kVA	44 kVA	55 kVA
Max. AC output current	41.8 A	50.2 A	55.2 A	60.2 A	66.9 A	83.6 A
Rated AC output current(at 230V)	36.2 A	43.5 A	47.8 A	52.17 A	58 A	72.5 A
Rated AC voltage	3 / N / PE, 220 / 380 V, 230 / 400 V					
AC voltage range	312 ~ 480 V					
Rated grid frequency	50 Hz / 60 Hz					
Grid frequency range	45 – 55 Hz / 55 – 65 Hz					
Harmonic (THD)	< 3 % (at Rated power)					
Power factor at Rated power / Adjustable power factor	> 0.99 / 0.8 leading – 0.8 lagging					
Feed-in phases / connectio n phases	3 / 3-N-PE					
Efficiency						

Parameter s	SG25C X-P2 ⁽⁴⁾	SG30CX -P2 ⁽⁴⁾	SG33C X-P2 ⁽⁴⁾	SG36CX -P2 ⁽⁴⁾	SG40CX -P2 ⁽⁴⁾	SG50CX -P2 ⁽⁴⁾
Max. efficiency / European efficiency	98.4% / 98.2%			98.5% / 98.3%		
Protection						
Grid monitoring				Yes		
DC reverse co nnection p rotection				Yes		
AC short- circuit protection				Yes		
Leakage current protection				Yes		
Surge protection			DC Type I+II / AC Type II			
Ground fault monitoring				Yes		
DC switch				Yes		
PV String current monitoring				Yes		
Arc fault circuit interrupter (AFCI)				Yes		
General Data						
Dimension s (W*H*D)			645*575*245 mm			

Parameter s	SG25C X-P2 ⁽⁴⁾	SG30CX -P2 ⁽⁴⁾	SG33C X-P2 ⁽⁴⁾	SG36CX -P2 ⁽⁴⁾	SG40CX -P2 ⁽⁴⁾	SG50CX -P2 ⁽⁴⁾
Mounting Method	Wall-mounting bracket					
Weight	38 kg		40 kg		40 kg	41 kg
Topology	Transformerless					
Degree of protection	IP66					
Corrosion	C5					
Operating ambient temperatu re range	-30 to 60 °C					
Allowable relative humidity range (non- condensin g)	0 – 100 %					
Cooling method	Smart forced air cooling					
Max. operating altitude	4000 m					
Display	LED, Bluetooth+APP					
Communi cation	RS485 / WLAN / Optional: Ethernet					
DC connectio n type	EVO2 (Max. 6 mm ²)					
AC connectio n type	OT terminal (16~35 mm ²)					OT or DT terminal (35~50 mm ²)

Parameter	SG25C	SG30CX	SG33C	SG36CX	SG40CX	SG50CX
s	X-P2 ⁽⁴⁾	-P2 ⁽⁴⁾	X-P2 ⁽⁴⁾	-P2 ⁽⁴⁾	-P2 ⁽⁴⁾	-P2 ⁽⁴⁾
AC Cable specification	Outside diameter 18~38mm					
Grid Support	Q at night function, LVRT, HVRT, active & reactive power control and power ramp rate control					

Note(4): For Latin America.

Note(5):

- The voltage difference between MPPTs should be less than 80 V.
- The voltage of the configured string should be higher than the lower limit of the rated MPPT voltage.

Note(6): 30kVA for Germany, Belgium, Austria, Ukraine and Denmark, 33kVA for others.

10.2 Wiring Distance of DI Dry Contact

The wiring distance between DI dry contact terminals must meet the requirements in the table below. The wiring distance L is the total length of all DI signal cables.

$$L = 2 \sum_{k=1}^n L_k$$

L_k refers to the cable length in one direction between the DI dry contact terminal of the k^{th} inverter and the corresponding terminal of the $(k-1)^{\text{th}}$ inverter.

Table 10-1 Correspondence Between Inverter Quantity and Maximum Wiring Distance

Number of Inverter	Maximum Wiring Distance(unit:m)	
	16AWG / 1.31mm ²	17AWG / 1.026mm ²
1	13030	10552
2	6515	5276
3	4343	3517
4	3258	2638
5	2606	2110
6	2172	1759
7	1861	1507

Number of Inverter	Maximum Wiring Distance(unit:m)	
	16AWG / 1.31mm ²	17AWG / 1.026mm ²
8	1629	1319
9	1448	1172
10	1303	1055
11	1185	959
12	1086	879
13	1002	812
14	931	754
15	869	703
16	814	660
17	766	621
18	724	586
19	686	555
20	652	528
21	620	502
22	592	480
23	567	459
24	543	440
25	521	422

NOTICE

In case the specification of the cable used is not included in the table above, when there is only one inverter, ensure that the line impedance of the input node is less than 300Ω; and when there are multiple inverters connected in the daisy chain, ensure that the impedance is less than 300Ω/number of inverter.

10.3 Quality Assurance

When product faults occur during the warranty period, SUNGROW will provide free service or replace the product with a new one.

Evidence

During the warranty period, the customer shall provide the product purchase invoice and date. In addition, the trademark on the product shall be undamaged and legible. Otherwise, SUNGROW has the right to refuse to honor the quality guarantee.

Conditions

- After replacement, unqualified products shall be processed by SUNGROW.
- The customer shall give SUNGROW a reasonable period to repair the faulty device.

Exclusion of Liability

In the following circumstances, SUNGROW has the right to refuse to honor the quality guarantee:

- The free warranty period for the whole machine/components has expired.
- The device is damaged during transport.
- The device is incorrectly installed, refitted, or used.
- The device operates in harsh conditions beyond those described in this manual.
- The fault or damage is caused by installation, repairs, modification, or disassembly performed by a service provider or personnel not from SUNGROW.
- The fault or damage is caused by the use of non-standard or non-SUNGROW components or software.
- The installation and use range are beyond stipulations of relevant international standards.
- The damage is caused by unexpected natural factors.

For faulty products in any of above cases, if the customer requests maintenance, paid maintenance service may be provided based on the judgment of SUNGROW.



Product data such as product dimensions are subject to change without prior notice. The latest documentation from SUNGROW should take precedence in case of any deviation.

10.4 Contact Information

In case of questions about this product, please contact us. We need the following information to provide you the best assistance:

- Model of the device
- Serial number of the device
- Fault code/name
- Brief description of the problem

For detailed contact information, please visit: <https://en.SUNGROWpower.com/contactUS>

SUNGROW

Sungrow Power Supply Co., Ltd.

www.sungrowpower.com